

## Development of the Limit Switch Box for a Ship and Its Performance Evaluation against Salt Water

Seung-Heui Lee\*, Seok-Jo Go \*\*, Min Cheol Lee \*\*\* , and Chang-Dong Kim \*\*

\* Interdisciplinary Program in Mechatronics, Pusan National University, Busan, Korea  
(Tel : +82-51-510-3081; E-mail: youneye@pnu.edu)

\*\*Division of Mechanical Engineering, Dongeui Institute of Technology, Busan, Korea  
(Tel : +81-51-860-3152; E-mail: sjgo@dit.ac.kr)

\*\*\*School of Mechanical Engineering, Pusan National University, Busan, Korea  
(Tel : +81-51-510-2439; E-mail: mclee@pusan.ac.kr)

**Abstract:** A limit switch box is used for an indicator of a valve actuator. This device indicates an opening and closing of a valve or a throttle in the valve actuator. In a ship, equipments require safety and robustness because of a rough environment and a specific condition during a voyage. However, the limit switch box has been used in an indoor environment generally. This study developed a new limit switch box which can be used at an outdoor environment. This study designed the new limit switch box. The housing of the limit switch box was made by an aluminum die cast method with surface painting after anodizing or chromate coating. In order to evaluate the endurance of the housing, the endurance tests against salt water have been conducted. Experiment results showed that the proposed device provides a reliable performance against salt water.

**Keywords:** Limit Switch Box, Valve Actuator, Surface Painting, Anodizing, Chromate

### 1. INTRODUCTION

Lots of devices and instruments are installed on a deck of ships for a safety voyage. A valve remote control system (V.R.C.S) is to control and operate a valve where is far from the system. The V.R.C.S consists of controller in control room, hydraulic/pneumatic actuator, solenoid valve, limit switch box, hydro-power unit, and etc.. A limit switch box transmits a mechanical or electrical signal related to the status of valves and actuators in a distance area to a main controller[1,2].

A limit switch box is used as an indicator for status of a valve actuator. This device indicates an opening and closing of a valve or throttle in a valve actuator. In a ship, equipments to be installed on a deck require a design for safety and robustness because of a rough environment and a specific condition during a voyage. However, the limit switch box has been used in an indoor environment generally.

Limit switch boxes for using mainly under the indoor environment have been produced by domestic maker. But in case of maritime purpose the whole quantity is imported from other countries and used.

In case of the ship and the chemical plant being different with general mechanical system the systems must have safety of system first of all because there are many dangerous environment and peculiarity. It is important that the systems should solve a safety problem due to corrosion and have long life maintenance.

This study designs and develops a new limit switch box which can be used under an outdoor environment like a ship. The limit switch box is designed detailly to endure under outdoor circumstance. A material to be suitable for a ship is selected. The housing of the limit switch box is made by an aluminum die cast method with surface painting after anodizing or chromate coating. In order to evaluate the endurance of the housing, the endurance tests against salt water have been done. Experiment results showed that the proposed device provides a reliable performance against salt water.

As there is recently increasing concern about system control at remote place, the preceding research has been studied a plan to recognize the open/close condition of valve used for a ship at remote place[1]. The first plan is a method to measure the flow rate supplied actually into actuator using volumetric flow meter, and the second plan is a method to check open/close condition of valve by installing indicator at valve axis. Using volumetric flow meter is favorable in installation and maintenance because it has problems due to limitation of installation space and maintenance to attach indicator which is the second plan. Fig. 1 shows a block diagram for remote valve control system to monitor whether a valve at a ship is opened or closed at remote place. The remote valve control device at main control room consists of controller, hydraulic/pneumatic actuator, solenoid valve, limit switch box, hydro-power unit, and etc.. The limit switch box plays an important role of sending the condition of valve and actuator at remote place to the main control room in mechanical and electrical signal[1,2]. Fig. 2 shows limit switch box, actuator, and etc. which are configuration element of the remote valve control system.

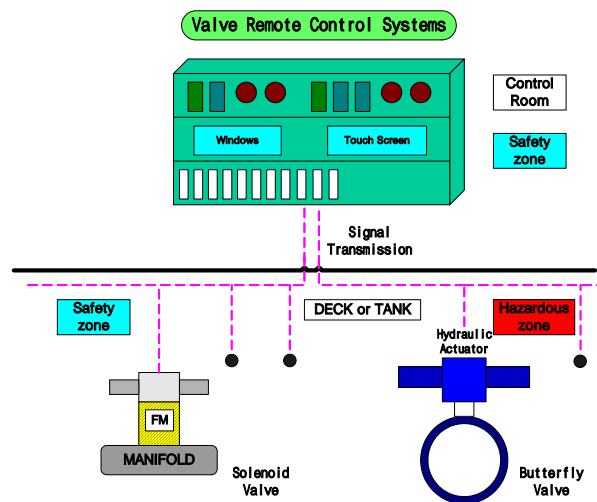

Fig. 1 Remote valve control system.

### 2. LIMIT SWITCH BOX

#### 2.1 Valve Remote Control Systems

2.2 Limit Switch Box

Limit switch box is attached to the upper part of hydraulic/pneumatic actuator in order to drive the valve which controls the flow of fluid inside pipe. The measured signals of open/close level of valves and actuators are transferred to a control room. In Fig. 2 the black and red cross type round case is a limit switch box, and Fig. 3 shows the limit switch box attached on the valve. The outside structure of the limit switch box consists of a case of plastic material to visually show open/close status, and the inside consists of cam shaft and small limit switch or potentiometer. Here, a signal from small limit switch is outputted to the mechanical contact point, and a potentiometer detects a signal of continuous open/close level. The detected signal is sent to the control room. The limit switch box being produced in domestic country is fabricated for being used mainly at indoor environment. Especially, this is often used as location indication of HQ-series actuator, and is divided into potentiometer type or relay contact point type depending on signal output method. However, equipment at a ship and a chemical plant shall need the highest priority on system safety due to environmental risk and better particularity than general mechanical equipment. Therefore, it is necessary to develop a limit switch box which guarantees durability and safety to be used in outdoor environment having particularity such as a ship, a chemical plant, etc. Table 1 shows size of domestic market of limit switch box. Table 2 shows situation of domestic and overseas production makers of limit switch box.



Fig. 2 Limit switch box and valve actuator assembly.

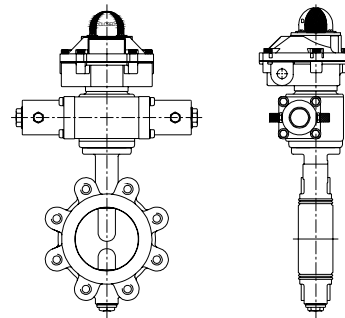

Fig. 3 Limit switch box, actuator and butterfly valve.

Table 1 Market of a limit switch box.

Section	2003	2004
International Market	1.6 Million \$	1.8 Million \$
Domestic Market	0.5 Million \$	0.6 Million \$

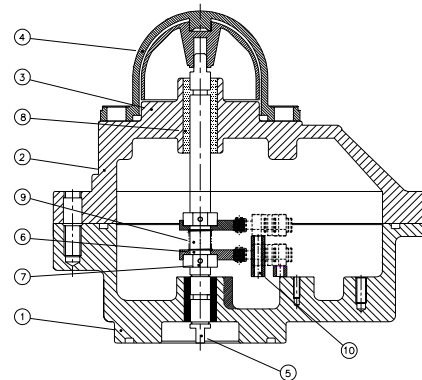

Fig. 4 Schematic diagram of the limit switch box.

Table 2 Company of a limit switch box.

Maker	Model	Market Share	Remark
HKC	APL 3N/4N	30 %	High Cost
ASCO	VRAG2Y1B1	30 %	Low Cost
DJ AP	AS710AP	20 %	-
ALPHA	SLS10	20 %	-

Table 3 Description of the limit switch box.

ITEM	Descriptions	Material
1	Main housing body	Al
2	Housing cover	Al
3	Position indicator	ABS
4	Position indicator cover	PC
5	Shaft	STS 316L
6	Cam	ABS
7	Cam holder	PC
8	Bush	Bronze
9	Spring	STS 304
10	Support	PC

### 3. DEVELOPMENTS OF LIMIT SWITCH BOX FOR A SHIP

#### 3.1 Design of the limit switch box for a ship

This study designs a limit switch box as shown in Fig. 4. The limit switch box composes each component as shown in Table 3. The limit switch box is designed by being divided into indication part, housing part, and internal switch part. The indication part is a device to confirm the status of valve and actuator at local region, and the switching part serves to convert valve and actuator status into signals and then send it to the control room at remote place. The housing part protects the switching part from the effect of external environment. The housing part is designed by being divided into switch box body and switch box cover. The internal switching part is designed in the cam shaft method being mechanical contact point type, the limit switch method being electrical resistance type, and the different methods using proximity switch and so on. In switching method, the small limit switch has simple structure to generate a signal as mechanical contact point, but can cause wear due to friction. Proximity switch generates signal through non-contact between shaft and switch, so it has strong durability, but requires anti-explosion product. Potentiometer generates voltage and current signals of continuous open/close level, in order to show continuous level rather than simple open/close status. Accordingly, in case of using limit switch box, it was designed suitably for installation environment by considering such characteristics.

#### 3.2 Material of the limit switch box

Materials for each part was determined as shown in Table 3 in order to fabricate prototype product of the limit switch box. Anti-corrosive material for the housing part of a limit switch box should be designed to reduce corrosion affected by external environment. However, in case of using anti-corrosive material, it has disadvantage due to price increase according to fabrication of housing. Therefore, the housing part of the limit switch box is fabricated by using aluminum die-casting mold. During the fabrication process of housing part, the product was molded by aluminum die-casting mold instead of corrosive material for the machining convenience during development process, and the housing part was designed to protect coating with powder painting through anodizing and chromate treatment for anti-corrosion against external environment. Fig. 5 shows the external shape of housing part which is fabricated by aluminum die-casting mold. Internal components are mainly used by STS 316 which is anti-corrosive material. STS 316 is a stainless steel of austenite system, a representative kind of stainless, which has 16%Cr-10%Ni-2%Mo composition, no magnetic property, excellent anti-corrosive property, high temperature strength, no hardening property by heat treatment, and excellent mechanical property[3]. Especially, in case of fabricating products using precise casting mold, this has good forming property and surface roughness in order to be suitable for mass production. Fig. 6 shows the inside of the limit switch box which is assembled together with switching part. Next, the indication part to indicate open/close position of valve was injection-molded using poly carbonated material in order to be furnished with solidity against external shock and visual transparency. Fig. 7 shows the external shape of fabricated indication part.

The developed limit switch box was designed as two kind type, mechanical switch type and potentiometer type. Fig. 8 shows the external shape of the developed limit switch box.

The model VIP C is contact point type, and the model VIP R is potentiometer type. Table 4 shows main specification of each item

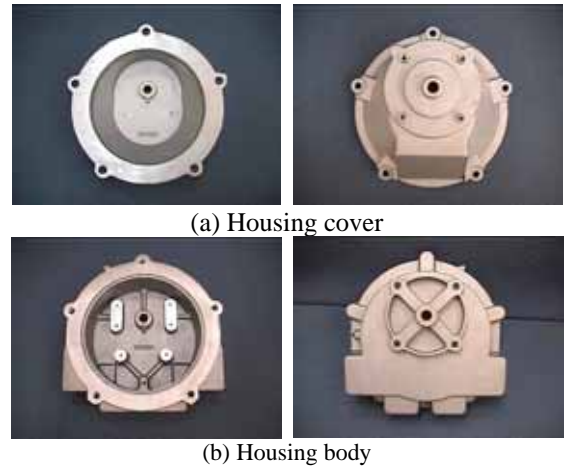

Fig. 5 Main housing of the limit switch box.



Fig. 6 Inner part of the limit switch box.



Fig. 7 Indicator of the limit switch box.

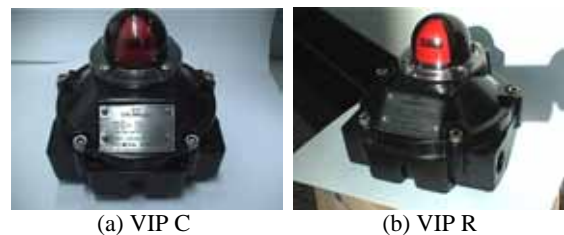

(a) VIP C (b) VIP R

Fig. 8 The developed limit switch box.

Table 4 Specifications of the development limit switch box.

Model	VIP C	VIP R
Enclosure	Weather proof, IP67	
Temperature range	-60 ~ +200	
Cable entry	NPT 2 × 1/2", NPT 2 × 3/4"	
Terminal strips	8 points	
Position indicator	0 ~ 90 °	
Switching type	Mechanical switch	Potentiometer 1 kΩ standard
Voltage	Max. 250V AC	
Painting	Powder coating with black color	

#### 4. METHODS OF NEUTRAL SALT SPRAY TESTING

##### 4.1 Corrosion

Sea water generally gives more severe corrosion than fresh-water, because sea water is electrolyte solution being likely to cause electro-chemical corrosion for various reasons. A corrosion of a ship to navigate on the ocean is severe due to complete exposure in sea-wind. Especially, during night, the strong electrolyte containing a lot of salt condenses on the deck due to temperature drop to cause local corrosion[4]. Other factors of corrosion include temperature, salt, concentration, PH, water contaminants, flow speed, etc., of which the chloride ion contained in sea water often causes corrosion by destroying the protection film for the metal having good anti-corrosive property.

##### 4.2 Anti-corrosion technology

Rust layer proceeds with continuous corrosion due to external environment, so the anti-corrosion technology for preventing this is essential for ships. The anti-corrosion technique for metallic material used in iron widely include as a technique for changing a metal property for adjusting alloy component according to environment and the surface protection technique to make coating on the iron surface. It is possible remarkably to save maintenance cost of metallic structure economically by applying such two kinds of anti-corrosion techniques according to proper method. The anti-corrosion method for general steel structure which is most widely used at present is a painting technique to make protection film on the surface. In the past, a simple painting showed sufficient anti-corrosion effect because the surrounding environment was not inferior like present. But now the other anti-corrosion methods are used because environment became inferior due to various pollutive materials such as acid rain, sulfurous acid gas, etc.[5]. The methods are as follows: the metallic plating method and the electric anti-corrosion method, which apply metallic component having high price of technical level anti-corrosion

property on the steel material, the anti-corrosion method of organic, and inorganic coat lining method, etc..

##### 4.3 Process of neutral salt spray testing

Factors which can have effect during operation of limit switch box include dust, sand, salt water spray, wind, etc. The problems which may appear in the limit switch box due to such effect are as follows: First, electrical characteristics change due to bad contact, change of contact resistance, etc.. Second, this interferes with movement of bearing, axis, shaft, and other moving components. Third, this can cause surface wear(corrosion, erosion). Forth, this can cause contamination to lubrication oil. And, other environmental factors such as steam can have effect on product corrosion, mold growth, and etc., when dust and sand are mixed. Combination of humid heat and chemically offensive dust in the atmosphere can cause corrosive reaction, and spraying of salty water in the atmosphere can cause similar effect. For example, this includes the effect of corrosive dust generated by ion such as ice-making salt. Therefore, the demand for internationally recognized authorization test is increasing in order to evaluate the performance of components pursuant to such various factors. Accordingly, the salt water spraying test evaluation was requested to the Korea Industrial Technology Test Institute which is KOLAS authorized institution in order to evaluate the effect of the developed product in the outdoor environment such as ocean. Salt water spraying test was performed according to the KS D 9502 standard[6,7].

##### 4.4 Results of neutral salt spray testing

Two sets of prototype products developed in this study and 1 set of existing product used on land at present were chosen as the specimen for salt water spraying test. The salt water spraying test conditions and each result comparison are shown in table 5 and Fig. 9, respectively. Fig. 9 shows that corrosion occurred at the housing part of all specimens, but anticorrosive property is good as being compared with existing product in case of chromate treated prototype product. Especially, the anticorrosive property of trial product fabricated is good in the part where bolt is joined to assemble the upper cover and lower case of the limit switch box and the corner part extruding to outside. However, some ship maker can request the complete method even if the price of product is high. In such case, it is expected that a maker should completely solve such corrosion problem by fabricating the housing part of the limit switch box using stainless steel which has excellent anti-corrosive property.

Table 5 Testing conditions and results.

Class	Composition	Result	Remark
Sample 1	AL, Anodizing(50 μm), Powder Painting	corrosion usual	VIP
Sample 2	AL, Chromate, Powder Painting	corrosion rare	VIP
Sample 3	AL, Anodizing(30 μm), Powder Painting	corrosion deep	existing product



Fig. 9 Testing results.

### 5. CONCLUSION

This study addressed development of a limit switch box which can be used in special external environment such as a ship. For this, first the detail design for the limit switch box was performed, and prototype product was fabricated by selecting the suitable material for a ship. And, the salt water spraying test for the prototype product developed in this study was performed in order to evaluate environmental effect which appears when being used in a ship. The result of performance test showed that the anticorrosive property of the prototype product which was treated for anodizing and chromate is excellent as compared with the housing part of the existing type which was fabricated by aluminum die-casting, plating, and powder painting. Accordingly, when fabricating mass product of the limit switch box for ocean based on test evaluation, it is possible to supply various limit switch boxes suitable for the demand from a ship maker. And, it is expected to have replacing effect of import and high price competitiveness through development of the limit switch box for ship.

### ACKNOWLEDGMENTS

This research was financially supported by the Technology Innovation Program through the Busan & Ulsan Small and Medium Business Administration.

### REFERENCES

- [1] Lee, S. H., Lee, M. C., Go, S. J., Jang, Y. S., and Choi, M. H., "A Study on Development of a Noncontact Precision Flow-meter Using MR Sensor and PIC," *Proceedings of the Korean Society of Precision Engineering Conference*, pp. 1063-1066, 2003.
- [2] Lee, S. H., Go, S. J., Lee, M. C., Kim, H. S., and Kim, C. D., "A Study on the Design of the Limit Switch Box for a Ship," *Proceedings of the KSME Autumn Meeting*, pp. 899-903, 2004.
- [3] Lee, M. K., Sim, J. H., and Paik, I. H., "Evaluation of Cutting Characteristics for Hot-Drilling of Stainless Steel," *Proceedings of the Korean Society of Precision Engineering Conference*, pp. 287-290, 2002.
- [4] Kim, Y. H., "Corrosion Status of Marine Structures and Applicable Protection Methods for Those

Erosion-Corrosion Environments," *Journal of the Korean Society of Marine Engineers*, Vol. 23, No. 1, pp. 1-8, 1999.

- [5] Kim, J. W., "Protection Technology by Coating and Lining," *Journal of the Korean Society of Marine Engineers*, Vol. 24, No. 5, pp. 1-15, 2000.
- [6] KS D 9502, METHODS OF NEUTRAL SALT SPRAY TESTING(NEUTRAL SALT, ACETIC ACID AND CASS TEST)
- [7] ISO 9227:1990, Corrosion tests in artificial atmospheres -- Salt spray tests