

Obstacle Avoidance Using Velocity Dipole Field Method

Sudath. R. Munasinghe*, Changmok Oh**, Ju-Jang Lee*** and Oussama Khatib****

* Department of Electronic and Telecommunication Engineering, University of Moratuwa, Sri Lanka
(Tel: 94-11-2650301 ext 3311; E-mail: rohan_munasinghe@ieee.org)

** Department of Electrical Engineering and Computer Science, KAIST, Daejeon, Korea
(Tel: +82-42-869-5432; E-mail: cmoh@kaist.ac.kr)

*** Department of Electrical Engineering and Computer Science, KAIST, Daejeon, Korea
(Tel: +82-42-869-3432; E-mail: jjlee@ee.kaist.ac.kr)

**** Department of Computer Science, Stanford University, USA
(Tel: +1-650-723-9753; E-mail: khatib@cs.stanford.edu)

Abstract: The velocity dipole field method is presented for real-time collision avoidance of mobile robots. The direction of motion of the obstacle is used as the axis of the dipole field, and the speed of the obstacle is used to proportionally strengthen the dipole field. The elliptical field lines of the dipole field are useful to skillfully guide the robot around obstacles, quite similar to the way humans avoid moving obstacles. Field modulation coefficient is also introduced to weaken the field effect as the obstacle recedes. The real-time algorithm of the velocity dipole field has been devised and experimentally tested on the robot soccer test-bed. The results show the capability of the new real-time collision avoidance strategy and how it can overcome the weaknesses in the conventional potential field method. The new method makes an explicit and proactive action of collision avoidance, unlike the conventional method, which forces the robot merely away from the obstacle aimlessly. The proposed method delivers greater capability with no considerable computational overhead

Keywords: Real-time collision avoidance, velocity dipole field, proactive navigation, moving obstacles, human skill

1. INTRODUCTION

Mobile robot navigation in dynamic environments is a complex task, which is generally implemented as a hierarchical control system [1]. At the highest level of the hierarchy, a global path is planned using expert knowledge or methods from artificial intelligence, and uses that path as a recommendation (not as a mandate) for the lowest level in the hierarchy, where real-time feedback control of steering and speed take place. The lowest level of the hierarchy keeps watching the local surrounding through sensor feedback such as sonar and laser range finders, and tries to avoid such obstacles (if any) that have not been taken into account by the global path planner. These obstacles may contradict with the recommended path, thus, the real-time path modifications are required to evade them.

The local obstacle avoidance is dominantly based on potential field methods that assign repulsive potential fields for obstacles, and an attractive field for the goal. These individual fields are superimposed to construct the potential landscape in which the robot moves downhill, probably towards the goal. The simple structure of potential field method makes it appropriate for real-time collision avoidance, with extendability to higher dimensions as well. However, potential field method could trap in local potential wells that could have been created after superimposition of individual fields. Oscillatory motion through narrow passages and difficulty in entering through door-frames are also typical problems of conventional potential field method [4].

Ironically, most of these drawbacks appear partly due to the implementation of potential field methods in static environments, for which a global path planner alone would be quite adequate, such as the nearness diagram method [7], and vector field histogram method, where the obstacle distribution is used to create navigation maps and guide the robot through safe areas and narrow passages. The local minima problem of potential field method has been addressed by Khosla, using superquadric potential functions to design local-minima-free potential landscapes for static obstacles. For the same purpose Koditschek [8] investigated function topologies to create a

unique potential minima at the goal for an arbitrary number of obstacles assuming that they have disjoint potential functions.

In this paper, we introduce the velocity dipole field method and demonstrate how it could be used to devise an explicit navigation strategy for real-time collision avoidance. The proposed method has the capability of navigating the robot skillfully, similar to the way a human would move to avoid an obstacle that approaches a collision path. The expected performance is quoted as follows:

“If the obstacle approaches fast, and is in a collision path, turn towards it, go around, and behind it while keeping a safe distance”.

This behavior has been explicitly realized using the proposed velocity dipole field, and a real-time collision avoidance algorithm has also been developed. Unlike the radial field lines of conventional potential field, the velocity dipole field has elliptical field lines that navigate a robot more skillfully. A novel feature of the velocity dipole field method is its feedforward (proactive) nature, which is quite the opposite to other reported works on collision avoidance that are inherently passive and feedback in nature (i.e., navigation decision is taken after obstacle has changed its position). Intelligent control techniques [10] may also be able to realize similar capabilities compared to that of the proposed method, however, with a huge computational overhead as they work with databases of knowledge and rules, whereas the proposed velocity dipole field method delivers such capabilities with no considerable computational cost.

Surpassing the results of [11], [13], and [12], we have demonstrated 60Hz implementation of the proposed velocity dipole field method on the robot soccer testbed, using small holonomic soccer robots. This speed is actually the maximum frame speed of the vision system, the proposed algorithm can operate even faster. The demonstrated skillful navigation capability could be used for modern applications such as for robots that inhabit human-populated environments, and for semi-autonomous vehicle fleets controlled by few human operators. The method could also be used as part of the

subsumption behavior architecture of intelligent mobile robots.

2. PROPOSED ALGORITHM FOR REAL-TIME OBSTACLE AVOIDANCE

We propose the velocity dipole field and its integration with the conventional potential field to form a new real-time obstacle avoidance algorithm. Figure 1 illustrates the three potential vectors that act on the robot in that U_p , U_v , and U_g are the force due to the conventional potential field, force due to the velocity dipole field, and the force due to the goal, respectively. By integrating the two fields we intend to deal with any obstacle—static, slow, or fast. The details of how this capability is achieved will be described shortly. The conventional potential field is analogous to the field of a static +ve electric charge. It extends radially outwards while decaying with distance. The radial field lines of the conventional potential field could be used to repel the robot away from the obstacle, which is a very basic attribute of collision avoidance. If the obstacle is static, or moving slowly, even this basic strategy is good enough to evade collision thought such a simple action does not manifest any skillful behavior. For a given distance, conventional field produces the same repelling force regardless of whether the obstacle is approaching or receding. Not making any use of the direction or speed of the obstacle, the method often gets trapped sending the robot off on a never ending detour around a moving obstacle.

On the other hand, the proposed velocity dipole field has elliptical field lines that can guide the robot skillfully around a moving obstacle, which can be manifested as an explicit skillful action of collision avoidance. The three forces

$$\begin{aligned} \mathbf{U}_p &= U_p \angle \theta_p^w \\ \mathbf{U}_v &= U_v \angle \theta_v^w \\ \mathbf{U}_g &= U_g \angle \theta_g^w \end{aligned} \quad (1)$$

are summed together, and the robot is navigated along the resulted force

$$\mathbf{U} = \mathbf{U}_p + \mathbf{U}_v + \mathbf{U}_g \quad (2)$$

The calculation of these forces will be explained shortly.

2.1 Skillful collision avoidance

To evade an approaching obstacle needs a proactive strategy of steering the robot in a more appropriate direction. The velocity dipole field shown in Fig.1 is capable of realizing

such a navigation strategy by using obstacle's velocity. Velocity dipole field possesses useful properties to realize skillful collision avoidance, similar to the way a human would avoid an obstacle that approaches a collision path. Following characteristics are expected to be aspects of skillful collision avoidance.

1) If the obstacle moves fast, the collision avoidance strategy should be activated at a greater distance, thereby not being too late to avoid collision. By strengthening the velocity dipole field in proportion to the speed, it is possible to fulfill this condition

2) If the obstacle moves fast, robot should let it pass first, and try to navigate around and behind it safely. As velocity dipole field is strong for fast obstacles, the elliptical field lines of the dipole field would guide the robot similar to this way.

3) If the obstacle moves slowly, robot should pass in front of it. As velocity dipole field is weak for slow obstacles, the conventional radial field would guide the robot similar to this way.

2.2 Field model

We speculate following model for both conventional potential field and proposed velocity dipole field.

$$U_i = q \eta_i e^{-\frac{1}{\alpha_i} d} \quad (3)$$

where U_i is the field potential, d is the distance between the obstacle and the robot. Symbols η_i , and α_i are intrinsic strength and decay variables of the fields, whereas q is the field modulation coefficient. The subscript $i \in \{p, v\}$ refers (3) to either conventional potential field, or velocity dipole field. The field modulation coefficient is intuitively modeled by

$$q = \frac{1}{4} \tanh\{\gamma(\phi_0 + \beta) + 1\} \times \tanh\{\gamma(-\phi_0 + \beta) + 1\} \in [0,1] \quad (4)$$

The field modulation is introduced to weaken the field strength as the obstacle recedes. The parameter β is the angle of the roll-off center, and γ is the roll-off rate. These two parameters could be manipulated to introduce various modulation effects into the potential field. Figure 2 graphically illustrates the field model, and modulation coefficient against the angle of approach $\phi_0 \in [-\pi, \pi]$ for tentative values of $\gamma = 3.0$ and $\beta = \pi/2$. The field-model in (3) assigns a finite potential even around close vicinity of the obstacle so that the

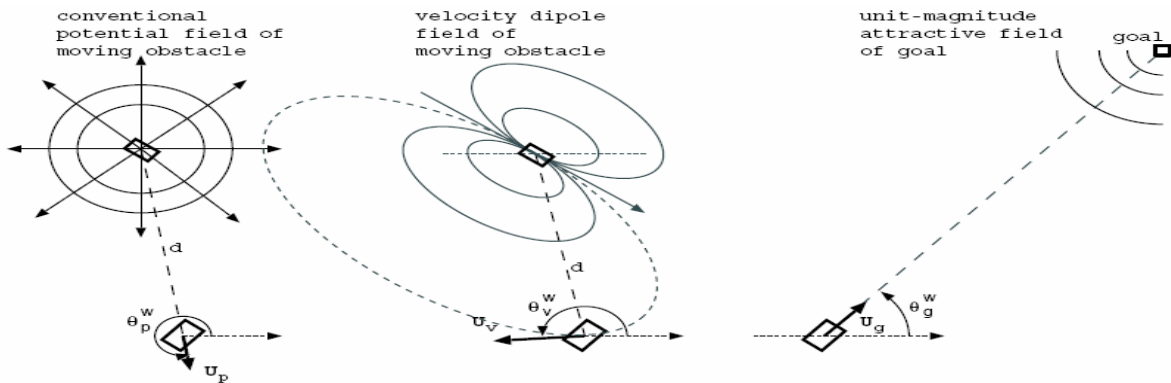

Fig 1 The potential field forces

navigation process can be physically realized without driving actuators to saturation. The parameters η_i and α_i should be selected in relation to the field strength of the goal so that the relative priorities for reaching goal and obstacle avoidance are properly traded-off. In other words, when the robot comes close to a moving obstacle a greater force should be felt from the obstacle that gradually and temporarily overrides the attractive force of the goal. It is also necessary that the speed of the obstacle be represented in the velocity field parameters η_v and α_v that can be defined using the speed ratio $k_v = v_o/v_a$, where v_o and v_a are obstacle's speed and assigned speed of the robot respectively. Considering these issues, following formulae are intuitively speculated to model the velocity dipole field parameters.

$$\begin{aligned} \eta_v &= k_f k_v \eta_g \\ \alpha_v &= k_v \eta_g \end{aligned} \tag{5}$$

in that η_g represents the magnitude of the goal potential, and $k_f (> 1)$ enhances the obstacle's field to be able to override the goal potential field at the close vicinity of the obstacle. Figure 2(a) illustrates field potential U_i modeled by (3), for $\eta_i = \alpha_i = 1$ and also shows how the field changes when these parameters are doubled. The parameters η_p and α_p of the conventional potential field are modelled similarly as follows

$$\begin{aligned} \eta_p &= k_f \eta_g \\ \alpha_p &= \eta_g \end{aligned} \tag{6}$$

which are independent of the speed ratio k_v . For simplicity, we assume that the potential field of the goal is of unit-magnitude ($\eta_g = 1$), and distance-independent.

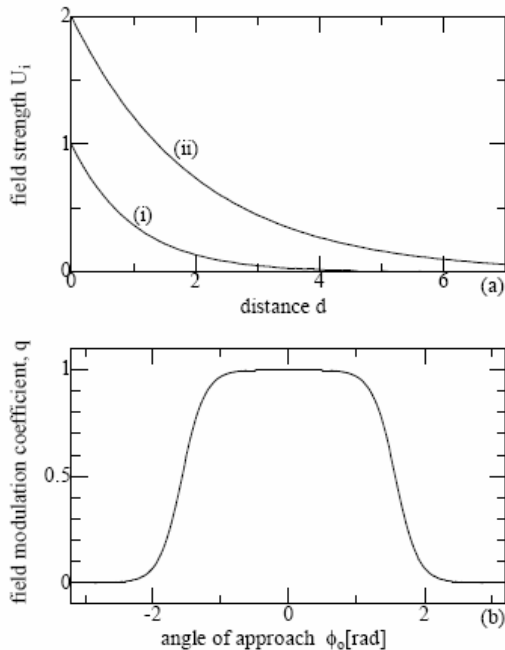

Fig 2 Potential Field model and field modulation coefficient q

2.3 Collision and goal reaching condition

1)Collision: If the robot is within a distance from the obstacle smaller than what the obstacle can cover in a unit time, it is

considered as a situation of possible future collision. Therefore we used the following condition

$$d < v_o \tag{7}$$

to signal the collision scenario, where $d = \sqrt{(x_r^w - x_o^w)^2 + (y_r^w - y_o^w)^2}$ is the distance between the robot and the obstacle. This criterion can be explained as follows: “-assume that the robot does not move, and the obstacle moves straight towards the robot, then (7) confirms a certain collision within the net time step-” Though it does not signal a certain collision in reality, it certainly signals the danger ahead. Given the possible errors of feedback signals and uncertain dynamics in the environment, this criterion provides a conservative measure of collision. Moreover, we never know where the obstacle should be heading in the next instant, therefore, we cannot use a measure of relative velocity to detect future collisions, therefore, we had better expect the worst case scenario.

2) Goal reaching: In a similar way as described above, goal reaching is confirmed by the condition

$$d_g < v_a \tag{8}$$

where $d_g = \sqrt{(x_r^w - x_g^w)^2 + (y_r^w - y_g^w)^2}$ is the distance between robot and the goal. The rationale for this condition is “-if the robot keeps its assigned speed, and moves straight towards the goal (8) confirms goal accomplishment within the next time step-”.

2.4 Real-time collision avoidance algorithm

Figure 4 illustrates the real-time implementation of the proposed collision avoidance strategy, highlighting the flow of calculations carried out in the real-time control loop of the mobile robot. The necessary equations for these calculations have been presented in earlier sections. Figure 3 has three branches flowing vertically downward, where the leftmost branch implements the proposed velocity dipole field. By disabling this branch, conventional potential field can be realized at any time. The calculations associated with the velocity dipole field involve no significant computational cost, therefore, it does not slow down the real-time response of the robot.

3. IMPLEMENTATION

3.1 Experimental tests on the robot soccer testbed

The proposed method was tested on the robot soccer platform, where one soccer robot (left) acts as the moving obstacle that travels across the field from left to right with a uniform speed of $k_v v_a$ and the other robot (bottom) runs the proposed obstacle avoidance algorithm (Fig.3) to navigate at constant speed v_a . An overhead video camera provides the position and heading of the two robots at a rate of 60fps (frames per second), and the navigation algorithm runs on a 2.4GHz Pentium IV PC. Soccer robots are holonomic, and driven by two wheels. The velocity command v_r in Fig.3 is used to determine the velocity commands for the two wheels as follows.

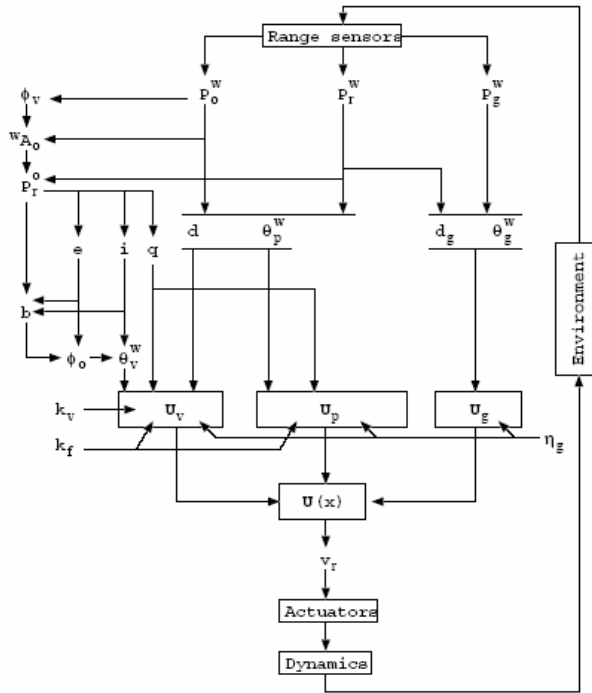

Fig 3 The proposed real-time collision avoidance algorithm

$$v_{right} = (2v_a + k_\omega \omega L) / 2$$

$$v_{left} = (2v_a - k_\omega \omega L) / 2$$
(9)

where $\omega = \angle \dot{v}_r$ is the angular speed of the resultant force, and $L = 7.5[\text{cm}]$ is the central axis length of the soccer robots. The angular speed gain $k_\omega = 0.01$ was set intuitively to realize satisfactory motion of the robot.

3.2 Test 1 : robot and obstacle have equal speeds

The collision avoidance capabilities of conventional potential field method and proposed method were tested when the obstacle and robot travel with the same speed ($k_v = 1$). The results are shown in Fig.6. In these tests the obstacle and robot were initially positioned at $(0\text{cm}, 80\text{cm}, \phi_v = 0 \text{ rad})$, and $(80\text{cm}, 0\text{cm}, \angle v_r = \pi/2)$ so that they were destined to collide. When running the conventional method $k_f = 25$ was used, as anything below this value failed to avoid collision. However, when running the proposed method, $k_f = 9$ was sufficient. Considering the physical dimensions of the robot soccer testbed, we set unit-distance and unit-speed to refer to 8[cm] and 8[cm/s] respectively.

As seen in Fig.4(a) the conventional potential field distracted the robot, and virtually carried away with it for a while. After the obstacle had sufficiently moved away, robot could turn back toward the goal, however, after making a lot of unnecessary driving. On the contrary, as can be seen in Fig.4(b), the velocity dipole field proactively steered the robot towards the approaching obstacle to drive around and behind it. Consequently, the energy of the velocity profiles and driving time were reduced. This behavior mimics human skill in collision avoidance.

3.3 Test 2 : fast and slow obstacle

The proposed method was tested against a fast obstacle ($k_v = 2$) and a slow obstacle ($k_v = 0.5$). The obstacle and robot

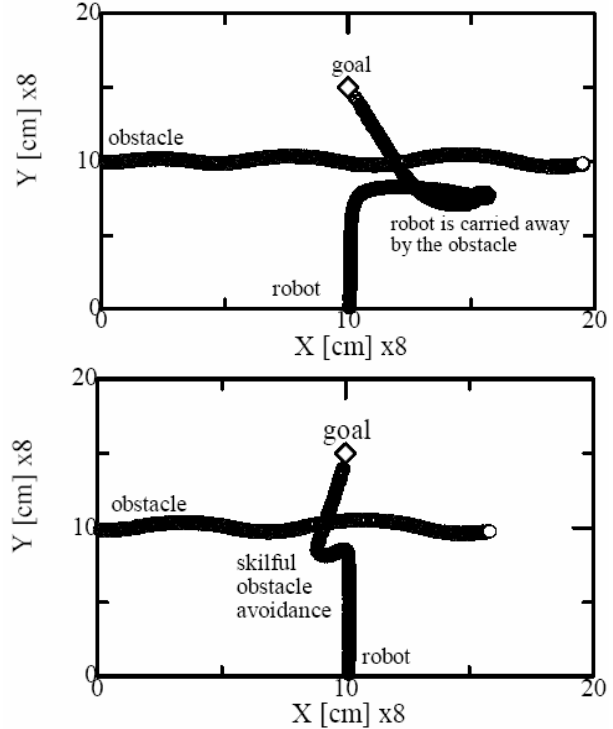

Fig 4 Experimental results of collision avoidance (conventional (upper) & proposed (lower) method)

were initially positioned so that they were destined to collide. A constant value of $k_f = 9$ was used in both trials. As the results in Fig.5 show, the robot accurately chose the passing behind strategy for the fast obstacle, and passing in front strategy for the slow obstacle, mimicking human skill in avoiding moving obstacles. The constraint of constant speed made obstacle avoidance more difficult. Nevertheless, velocity dipole field demonstrated satisfactory performance in all experimental trials. Speed control can therefore be considered as an additional feature that could be used to further improve the navigation performance. Similarly, intrinsic field strength was kept constant at $k_f = 9$, which could also be manipulated to improve the performance further.

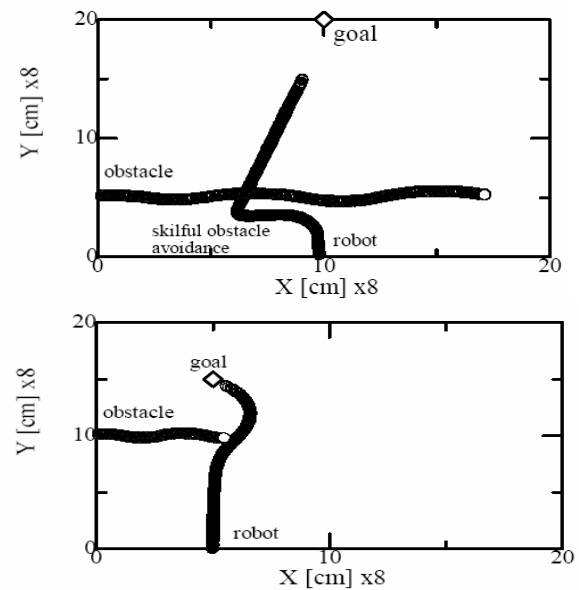

Fig 5 Performance of proposed algorithm with fast(upper) and slow(lower) obstacle

5. CONCLUSION

The velocity dipole field method has been presented and an efficient real-time collision avoidance algorithm has been devised for mobile robots. The method lets the robot mimic human skill of avoiding moving obstacles. The elliptical field lines of the velocity dipole field proactively guide the robot around, and behind fast obstacles. For a slow obstacle, this effect is weak, and the robot is driven in front of the obstacle by the stronger conventional potential field. Field modulation is also incorporated to weaken the potential fields as the obstacle recedes. The real-time implementation of the algorithm has also been devised, and tested experimentally on the robot soccer testbed. The proposed method has demonstrated skillful real-time navigation capability under the constraint of constant speed, and encountering with fast, equal-speed, and slow obstacles that are all destined to collide. Velocity dipole field method also helps lowering the energy of velocity profiles and driving time, that saves fuel consumption. The proposed obstacle avoidance strategy could be used specifically for autonomous robots that intend to inhabit human-populated environments.

ACKNOWLEDGMENTS

This paper was funded under the Brain Korea 21 project between KAIST and Stanford University.

REFERENCES

[1] K. Fujimura and H. Samet, "A hierarchical strategy for path planning among moving obstacles," *IEEE Tr. on Robotics and Automation*, vol. 5, no. 1, pp. 61-69, Feb., 1989.

[2] O. Khatib, "Real time obstacle avoidance for manipulators and mobile robots," *Intl. J. of Robotics Research*, vol. 5, no. 1, pp. 90-98, Oct., 1986.

[3] B. H. Krogh, and C. E. Thorp, "Integrated path planning and dynamic steering control for autonomous vehicles," *IEEE Intl Conf. on Robot. and Automat.*, pp. 1664-1669, May, 1986.

[4] R. B. Tilove, "Local obstacle avoidance for mobile robots based on the method of artificial potentials," *IEEE Intl Conf. on Robot. and Automat.*, pp. 566-571, May, 1990.

[5] Y. K. Hwang, and N. Ahuja, "A potential field approach to path planning," *IEEE Tr. on Robotics and Automation*, vol. 8, no. 2, pp. 23-32, Feb., 1992.

[6] O. Brock and O. Khatib, "Elastic Strips: A Framework for Motion Generation in Human Environments," *The International Journal of Robotics Research*, vol. 21, issue 12, pp. 1031-1052, Dec. 2002.

[7] J. Minguez and L. Montano, "Nearness diagram (ND) navigation: collision avoidance in troublesome scenarios," *IEEE Tr. On Robotics and Automation*, vol. 20, no. 1, pp. 45-59, Feb., 2004.

[8] P. Fiorini and Z. Ziller, "Motion planning in dynamic environments using the relative velocity paradigm," *IEEE Intl Conf. on Robot. and Automat.*, pp. 560-565, May, 1993.

[9] F. Large, Z. Ziller, and C. Laugier, "Using non-linear velocity obstacles to plan motions in a dynamic environment," *Intl. Conf. on Intl. Automat. Robot. and Vision*, pp. 734-739, Dec, 2002.

[10] M. Mucientes, R. Iglesias, C.V. Regueiro, A. Bugarin, P. Carinena, and S. Barro, "Fuzzy temporal rules for

mobile robot guidance in dynamic environments," *IEEE Tr. on Syst. Man, and Cyber. Part C*, vol. 31, no.3, pp. 391-398, Aug. 2001.

[11] D. Fox, W. Burgard, and S. Thrun, "The dynamic window approach to collision avoidance," *IEEE Robotics and Automation Mag.*, pp. 23-33, March, 1997.

[12] O. Brock, and O. Khatib, "High-speed navigation using the global dynamic window approach," *IEEE Intl. Conf. on Robot. and Automat.*, pp. 341-346, May, 1999.

[13] K. O. Arras, J. Persson, N. Tomatis, and R. Siegwart, "Real-time obstacle avoidance for polygonal robots with a reduced dynamic window," *IEEE Intl. Conf. on Robot. and Automat.*, pp. 3050-3055, May, 2002.