

## The Performance Improvement of Synchronous Machine with Digital Excitation System Control

H. M. Hong\*, J. H. Choi\*\*, B. S. Jeon\*\*, M. K. Min\*\*, J. G. Kim\*\*,  
I. H. Lim\*\*\*, H. S. Ryu\*\*\*\*

\*Department of Electrical & Electronic Engineering, Donghae University, Kangwondo, Korea  
( Tel: +82-33-520-9321; Fax:+82-33-521-9407; Email: hmhong@donghae.ac.kr)

\*\*School of Electrical & Computer Engineering, Chungbuk National University, Cheongju, Korea  
(Tel: +82-43-261-2419; Fax: +82-43-263-2419; Email: koamma88@chungbuk.ac.kr)

\*\*\*KEPRI(Korea Electric Power Research Institute)  
(Tel: +82-42-865-5114 )

**Abstract:** This paper deals with the design and evaluation of the robust controller for a synchronous generator excitation system to improve the steady state and transient stability. The nonlinear characteristics of the system is treated as model uncertainties, and then the robust control techniques are introduced into the power system stability design to take into account these uncertainties at the controller design stage. The performance of the designed controller is examined by extensive non-linear time domain simulation. It is shown that the performance of the robust controller is superior to that of the conventional PI controller. This paper also proposes an improved digital exciter control system for a synchronized generator using a digitally designed controller with database. Results show that the proposed control system manifests excellent control performance compared to existing control systems. It has also been confirmed that it is easy for the proposed control system to implement digital control.

**Keywords:** Robust control, synchronous generator excitation system, PI controller

### 1. Introduction

An excitation system consists of the main body, a generator and exciter equipment, which is divided into the AVR(Automatic Voltage Regulator) and exciter that provides the field current. The importance of the generator exciter system has been increased as the performance of power system continued to improve. A synchronous generator is equipped with an Automatic Voltage Regulator (AVR), which is responsible for keeping the generator output voltage constant under normal operating conditions at various load levels.

The problem of power system dynamic stability has been received growing attention over the past three decades. The main reasons for this attention are the increasing size of generating units and the use of high-speed excitation systems. The effect of the high-speed excitation on dynamic stability may cause steady state instability. Thereby, it is to add negative damping causing oscillations with weak damping[1]. In practical field, it has been relied on the lead-lag compensators of the classic control[2]. The LQ(Linear

Quadratic) control theory has been used by many researchers to design PSS[2,3]. Even through the nominal performance of LQ PSS is quite satisfactory, its robust stability and robust performance are shown to be poor[3]. Much efforts have been studied to the controller design of relevant PSS, which have been used root locus, eigenvalue techniques[4], pole placement[5], adaptive control[6], etc. But in all these methods model uncertainties cannot be considered at the controller. Recently, the robust control has applied to the power system stabilizer design, which consider the model uncertainties[7,8].

This paper deals with the design and evaluation of the robust controller for a synchronous generator excitation system to improve the steady state and transient stability. The performance of the designed controller is examined by extensive non-linear time domain simulation. It is shown that the performance of the robust controller is superior to that of the conventional PI controller. Results show that the proposed control system manifests excellent control performance compared to existing control systems.

It has also been confirmed that it is easy for the proposed control system to implement digital control with database.

In the next Section, we have processed the PSS system modelling, Convention modelling techniques are represented. In Section 3, robust controller design with the database is performed under the condition of uncertainties. Simulation results are illustrated in Section 4, and conclusions are followed in Section 5.

## 2. System Modeling and Controller design

### 2.1 System Modelling

The conventional PSS system has been modelled as a synchronous generator connected to an infinite bus through two parallel transmissions. Which is shown in Fig.1. Furthermore PI controller is usually utilized, for practical consideration PI controller has been replaced into the lead-lag controller. However to obtain robust performance against model uncertainties, we proposed robust controller with database. In Fig. 2, system configuration with robust control is illustrated.

Usually, PI controller is replaced by the lead-lag controller, where  $T_r$  is the transformer,  $E_t$  is the terminal voltage,  $\Delta w$  is the difference of angle degree,  $E_{fd}$  is the exciter voltage, and  $V_{ref}$  is the terminal voltage. The robust control PSS system is modelled as a synchronous generator connected to an infinite bus through two parallel transmission, as shown in Fig.2. Robust controller considers not only  $\Delta w$  but also  $P$ .

In Fig. 3, D-Q axis equivalent circuits of a synchronous generator are illustrated. The generator with arotisseurs is modeled as a 6th order non-linear differential equations as follows.

Stator voltage equations:

$$e_d = p\Psi_d - \Psi_q \cdot \omega_r - R_a \cdot i_d \quad (1)$$

$$e_q = p\Psi_q + \Psi_d \cdot \omega_r - R_a \cdot i_q \quad (2)$$

$$e_0 = p\Psi_0 - R_a \cdot i_0 \quad (3)$$

Rotor voltage equations:

$$e_{fd} = p\Psi_{fd} + R_{fd} \cdot i_{fd} \quad (4)$$

$$0 = p\Psi_{1d} + R_{1d} \cdot i_{1d} \quad (5)$$

$$0 = p\Psi_{1q} + R_{1q} \cdot i_{1q} \quad (6)$$

$$0 = p\Psi_{2q} + R_{2q} \cdot i_{2q} \quad (7)$$

where  $p$  is  $d/dt$ ,  $\Psi_d$  is the d-axis of stator flux linkage  $\Psi_q$  the q-axis of stator flux linkage respectively,  $R_a$  is armature resistance,  $\omega_r$  is the angle speed,  $i_d$  is the d-axis of stator current and  $i_q$  is the q-axis of stator current respectively,  $R_{iq}$  and  $R_{id}$  are the rotor circuit

resistances respectively,  $i_{id}$  and  $i_{iq}$  are the rotor current respectively.

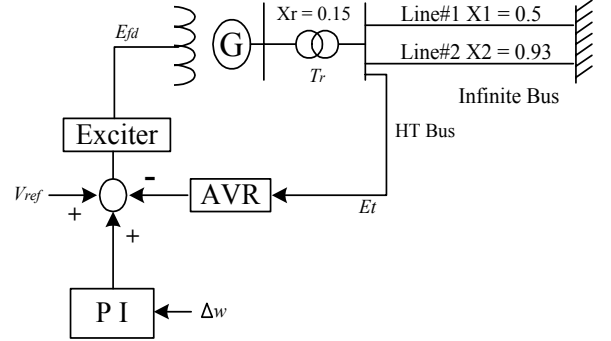

Fig 1. System configuration using the conventional PI control.

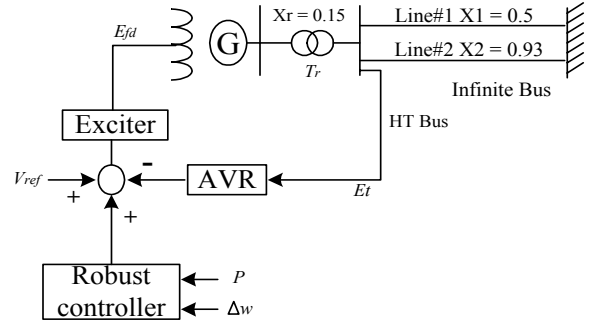
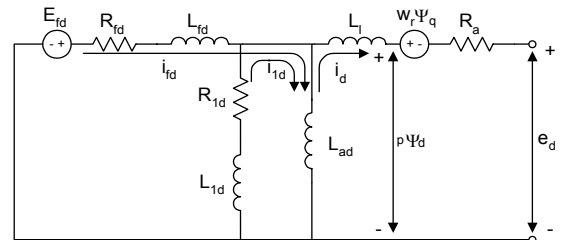
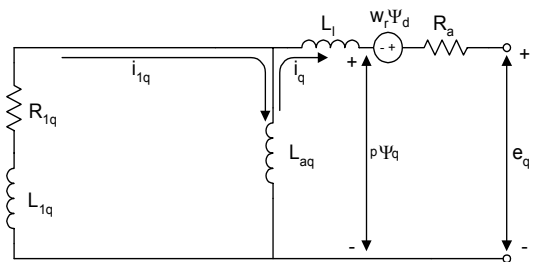

Fig. 2. System configuration using robust control.



(a) D-axis



(b) Q-axis

Fig. 3. D-Q axis equivalent circuit of a synchronous generator

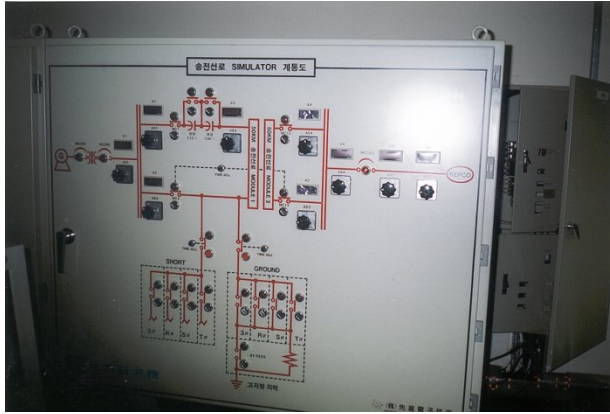

Fig. 4. Power transmission module

Table 1. 2[KVA] generator mechanical constant value

d-axis synchronous, reactance unsaturated	Xd	66.54
q-axis synchronous, reactance unsaturated	Xq	32.73
Open circuit time constant	T'do	189.82
d-axis transient reactance saturated	X'd	4.73
short circuit time constant	T'd	14.55
d-axis subtransient reactance saturated	X''d	2.36
Subtransient time constant	T''d	1.35
q-axis subtransient reactance saturated	X''q	4.07
Zero sequence reactance unsaturated	Xo	4.73
Negative sequence reactance unsaturated	X2	3.2

Power transmission module and 2[KVA] generator mechanical constant values are represented in Fig. 4 and Table 1.

## 2.2 Robust Control Theory

Robust control theory deals with control system design for dynamic systems with uncertainties in their models. A controller is said to be robust to a given set of system uncertainties if it provides stability and satisfactory performance for all system models in this set.

In power system, the main source of model uncertainties are due to the change in operating conditions. Uncertainties are usually represented in terms of a bound on magnitude of the frequency response of the nominal system. The relationship can be shown as:

$$G(s) = (I + \Delta_m(s))G_o(s) \quad (8)$$

where  $\Delta_m(s)$  is the multiplicative uncertainty, which usually has boundedness  $\Delta_m(s) < \gamma$ .

This relationship is shown in Fig. 5 with appropriate weighting functions  $W_1$  &  $W_3$ .

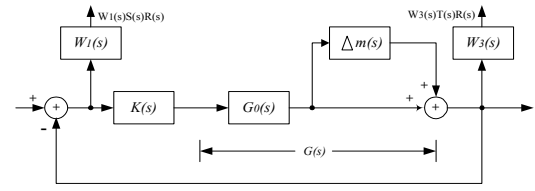

Fig. 5 Uncertainty model and the weighted sensitivity functions

Considering these weighting functions, we utilized the previous used operating data set. Weighting function is designed based on these operating data. To satisfy the control performance and sensitivity conditions, we select the weighting functions as follows

$$W_1(s) = \left[ 2.9 \frac{-s^2 + s + 1}{s + 4} \quad 4.5 \frac{-s^2 + s + 1}{s + 4} \right], \quad (9)$$

$$W_3(s) = \left[ \frac{1.0}{0.03} \frac{s + 10}{s^2 + s + 1} \quad \frac{0.9}{0.03} \frac{s + 10}{s^2 + s + 1} \right]. \quad (10)$$

Next, controller  $K(s)$  takes the following structure

## 3. Simulation and Experiment

The performance of the designed controller is examined by extensive non-linear time domain simulation. The simulation results have indicated that the robust controller can maintain the system stability under all operating conditions and can provide greater damping than the conventional PI controller.

In Fig. 6, a fault at high transmission is simulated. It is shown that the robust controller provides greater damping than the PSS. Fig. 7 shows the results of proposed robust controller. It shows the desired control performance while ensuring robustness for the uncertainty and disturbance contained in the power system.

## 4. Conclusions

This paper deals with the design and evaluation of the robust controller for a synchronous generator excitation system to improve the steady state and transient stability. The nonlinear characteristics of the system is treated as model uncertainties, and then the robust control techniques are introduced into the power system stability design to take into account these uncertainties at the controller design stage. The performance of the designed controller is examined by extensive non-linear time domain simulation. It is shown that the performance of the robust controller is superior to that of the conventional PI controller.

## References

- [1] P. Kundur, *Power system stability and control*, McGraw-Hill, Inc. 1995.
- [2] Y.N.Yu, *Power system Dynamics*, Academic Press, New York. 1983.
- [3] R. Asgharian and D.C. Macdonald, "The design of turbine-generators optimal controllers including the effects of torsional modes of oscillations," *IEEE Trans. Energy conversion*, vol.3, no.2, pp. 230~234, 1988.
- [4] P. Kundur, D. C Lee and H. M. Zein El-Din, "Power system stabilizers for thermal units: Analytical Techniques and on-site validation," *IEEE Transactions on Power Apparatus and Systems*, Vol. PAS-1, pp. 81-95. 1981.
- [5] H. Othman, J. J. Sanchez-Gasca, M. A. Kale and J. H. Chow, "On the design of Robust power system stabilizer," *Proceedings of the 28th Conference on decision and control*, Tampa, Florida, pp. 1853~1857, Dec. 1989.
- [6] Malik, O. P., Hope, G.S., Gorski, Y. M., Ushakov, V. A., Rackevich, A. L, "Experimental studies on adaptive microprocessor stabilizers for synchronous generator," *IFAC Power System and Power Plant Control*, Beijing pp. 125~130, 1986.
- [7] P. Kundur, M. KleinMalik, "Application of system stabilizers for enhancement of overall system stability," *IEEE Transactions on Power Systems*, Vol. PS-4, pp. 614~626. 1989.

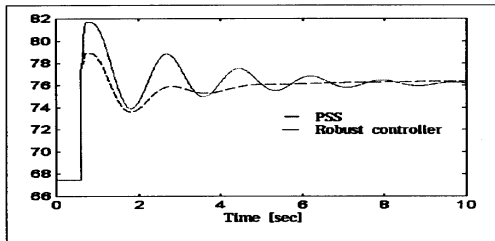

(a)

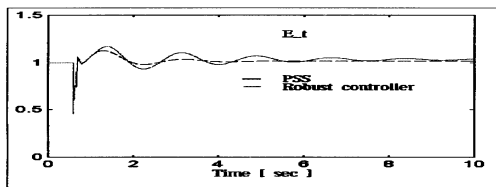

(b)

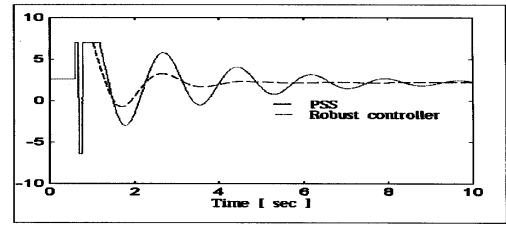

(c)

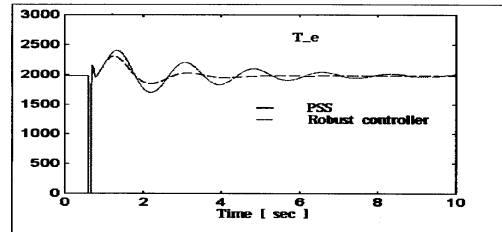

(d)

Fig. 6 Comparison Robust control and conventional PSS control (a)Electrical angle (b) Terminal voltage(c)Exciter terminal voltage (d)Electrical power

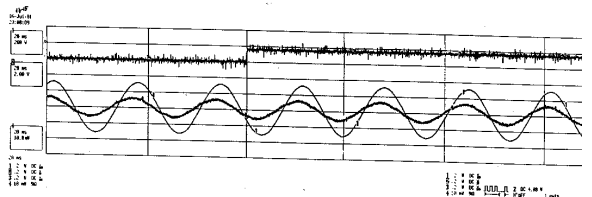

(a) Up step

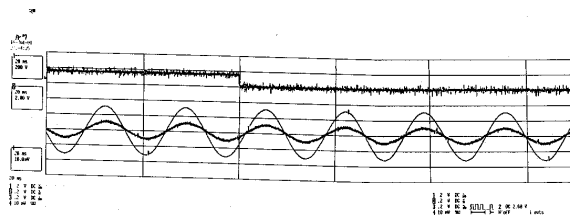

(b) Down step

Fig. 7. Experiment waveforms excitation current, terminal voltage and terminal current at power system connection:

1. Exciter reference current, 2. Terminal Voltage, 3. Terminal current