

## Sliding Mode Control of 5-link Biped Robot Using Wavelet Neural Network

Chul Ha Kim\*, Sung-Jin Yu\*, Jin Bae Park\* and Yoon Ho Choi\*\*

\* Department of Electrical & Electronic Engineering, Yonsei University, Seoul, Korea

(Tel : +82-2-2123-2773; E-mail: knight@control.yonsei.ac.kr, niceguy1201@control.yonsei.ac.kr, jbpark@yonsei.ac.kr)

\*\*School of Electronic Engineering, Kyonggi University, Suwon, Korea

(Tel : +82-31-249-9801; E-mail: yhchoi@kyonggi.ac.kr)

**Abstract:** Generally, biped walking is difficult to control because it is a nonlinear system with various uncertainties. In this paper, we design a robust control system based on sliding-mode control (SMC) of 5-link biped robot using the wavelet neural network(WNN), in order to improve the efficiency of position tracking performance of biped locomotion. In our control system, the WNN is utilized to estimate uncertain and nonlinear system parameters, where the weights of WNN are trained by adaptive laws that are induced from the Lyapunov stability theorem. Finally, the effectiveness of the proposed control system is verified by computer simulations.

**Keywords:** Biped Robot, Sliding Mode Control, Wavelet Neural Network, Model Reference Adaptive System

### 1. INTRODUCTION

As a biped robot has become more anthropomorphic and performs a various task on behalf of human, the research on biped robots gradually attracts much attention and is progressing dynamically. However, biped robots are difficult to control due to their nonlinear and coupled dynamics. First, Inverted pendulum [1] is applied to interpret some characteristics of human walking. Later, researchers construct a 3-link biped robot model [2], and a 5-link biped robot model [3,4].

In controlling biped robots, we face some problems such as instability of locomotion, high-order dynamic equation, existence of different phases of the walking cycle and various uncertainties. Due to these constraints, a biped robot requires a robust control technique having higher performance in spite of uncertainties comparing with standard PD control. So, a computed torque or inverse dynamics technique using feedback linearization [5,6] is proposed to control a biped robot. However, such methods are difficult to control a biped robot model with the model uncertainties. Therefore, the sliding mode technique for the robust control of a biped robot with uncertainties is proposed [7]. However, the sliding mode control (SMC) requires prior knowledge of the mathematical model and uncertainty bounds.

On the other hand, recently, wavelet neural networks (WNNs), which combine the capability of neural network [8-9] for learning from processes and the wavelet decomposition [10], are used as good estimation tools for the identification and control of dynamic system [11]. Training algorithm plays important role for WNN approximation. The gradient-descent (GD) method is used as conventional on-line training technique. However, the GD method is difficult to acquire sensitivity information for unknown or highly nonlinear dynamics and has the problem, which settles to the local minimum. So, training methodology, which is induced by Lyapunov stability theorem [12], has researched to ensure the stability, robustness, and performance of system.

In this paper, we propose WNN based SMC (WNNSMC) for the stable walking of 5-link biped robot with uncertainties. In our control system, wavelet neural network is employed to estimate uncertain and nonlinear functions of the 5-link biped robot. All weights of WNN are trained by the adaptation laws induced from the Lyapunov stability theorem, which are used to guarantee the stability of control system. Finally, in

order to verify the effectiveness and robustness of the proposed control technique, the performance of control scheme are proved by comparing the tracking performance of the WNNSMC with that of the SMC via the computer simulations.

### 2. THE 5-LINK BIPED ROBOTIC MODEL

#### 2.1 Kinematic model

The 5-link biped robot model used in this paper is shown in Fig. 1. Each link is connected by a rotating joint, which is driven by an independent DC motor.

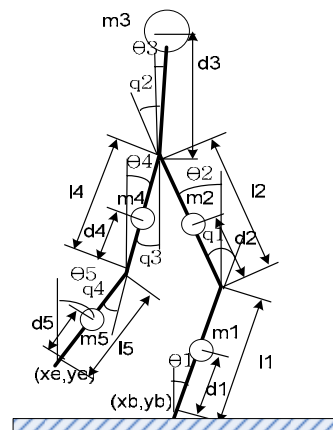

Fig.1 Biped in single support phase.

Parameters shown in Figure 1 are as follows:

- $m_i$  : Mass of link  $i$ ,
- $l_i$  : Length of link  $i$ ,
- $d_i$  : Distance between the mass center of link  $i$  and its lower joint,
- $I_i$  : Moment of inertia with respect to an axis passing through the mass center of link  $i$  and being perpendicular to the motion plane,
- $\theta_i$  : Angle of link  $i$  with respect to vertical (the positive direction of  $\theta_i$ ,  $i=1,2,3,4,5$ , is the one shown in the figure).

Relationship of link is expressed as

$$\begin{aligned} x_e &= x_b + l_1 \sin \theta_1 + l_2 \sin \theta_2 + l_4 \sin \theta_4 + l_5 \sin \theta_5 \\ y_e &= y_b + l_1 \cos \theta_1 + l_2 \cos \theta_2 - l_4 \cos \theta_4 - l_5 \cos \theta_5 \end{aligned} \quad (1)$$

Differentiating (1) with respect to time, we obtain

$$\begin{aligned} v_e = \begin{pmatrix} \dot{x}_e \\ \dot{y}_e \end{pmatrix} &= \begin{pmatrix} l_1 \cos \theta_1 \\ -l_1 \sin \theta_1 \end{pmatrix} \dot{\theta}_1 + \begin{pmatrix} l_2 \cos \theta_2 \\ -l_2 \sin \theta_2 \end{pmatrix} \dot{\theta}_2 \\ &+ \begin{pmatrix} l_4 \cos \theta_4 \\ -l_4 \sin \theta_4 \end{pmatrix} \dot{\theta}_4 + \begin{pmatrix} l_5 \cos \theta_5 \\ -l_5 \sin \theta_5 \end{pmatrix} \dot{\theta}_5 \end{aligned} \quad (2)$$

### 2.2 Dynamic model

It is assumed that the biped does not slip at the end of supporting without a friction. The biped robot model, which induced by the Lagrange dynamic model describing the motion of the biped in single support phase, represents as follows:

$$H(\theta) \ddot{\theta} + B(\theta, \dot{\theta}) + G(\theta) = \tau_\theta \quad (3)$$

where  $\theta = [\theta_1, \theta_2, \dots, \theta_5]^T$ ,  $\tau_\theta = [\tau_{\theta_1}, \tau_{\theta_2}, \dots, \tau_{\theta_5}]^T$ ,

$$B(\theta, \dot{\theta}) = \text{col} \left[ \sum_{j=1}^5 \left( h_{ij} (\dot{\theta}_j)^2 \right) \right],$$

$$G(\theta) = \text{col} [G_i(\theta)], \quad H(\theta) = [H_{ij}(\theta)] \quad (i, j = 1, 2, \dots, 5),$$

and  $\tau_\theta$  is generalized torque which is corresponding to each joint angle.  $H(\theta)$  is a  $5 \times 5$  symmetric positive-definite inertia matrix,  $B(\theta, \dot{\theta})$  is a  $5 \times 1$  column vector with respect to the Coriolis and centripetal torque, and  $G(\theta)$  is a  $5 \times 1$  gravity vector.

If  $q_1, q_2, q_3$  and  $q_4$  are relative angle deflections of the corresponding joint, then

$$q_1 = \theta_1 - \theta_2, q_2 = \theta_2 - \theta_3, q_3 = \theta_3 - \theta_4, q_4 = \theta_4 - \theta_5.$$

The torques are transformed as  $\tau_q = E \tau_\theta$ ,

$$\text{where, } E = \begin{bmatrix} 1 & 0 & 0 & 0 \\ -1 & 1 & 0 & 0 \\ 0 & -1 & 1 & 0 \\ 0 & 0 & 1 & 1 \\ 0 & 0 & 0 & -1 \end{bmatrix}.$$

Transformed by  $q$ , (3) is expressed as

$$H(q) \ddot{q} + B(q, \dot{q}) + G(q) = \tau_q. \quad (4)$$

In (4), we use the variables  $q_i (i = 0, 1, \dots, 4)$  instead of  $\theta_i (i = 1, 2, \dots, 5)$ , where  $q_0$  is the hypothetical joint 0.

$H(\theta)$ ,  $B(\theta, \dot{\theta})$ , and  $G(\theta)$  are in [7].

### 3. CONTROL OF THE BIPED ROBOT

In order to control the tracking performance of the biped robot effectively, the WNNSMC is proposed in this Section. First, we discuss a WNN structure used in the proposed control system. Second, the design methodology of WNNSMC system is discussed.

#### 3.1 Wavelet neural network

In this paper, we use two WNN estimators in each joint: the one is used to estimate a function of gravity, Coriolis and disturbance, and the other is to estimate a function of inertia matrix.

In our control system, we predict parametric variations and uncertainties in each joint. A proposed WNN structure is shown in Fig.2.

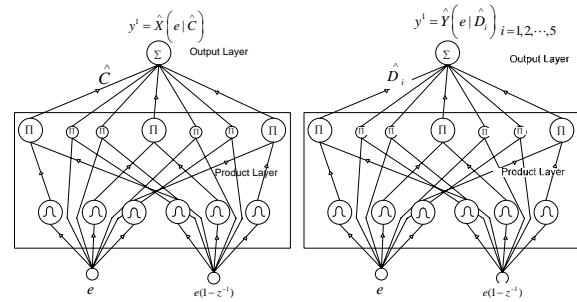

Fig. 2 Structure of wavelet neural network.

The signal propagation and basic function in the product layer is expressed as

$$y_i = \prod_j \phi(\text{net}_{jp}) \quad \text{with} \quad \text{net}_{jp} = \frac{x_p - m_{jp}}{d_{jp}}. \quad (5)$$

where  $x_p$  denotes the input of the WNN, and  $m_{jp}$ ,  $d_{jp}$  are translation and dilation vector of the product layer. Then, outputs sum products of training weight and output of mother wavelet function ( $\phi(x) = -x \exp(-x^2/2)$ )

$$y^o = \sum_j w_{jo} y_j, \quad \text{with} \quad j = 1, 2, \dots, n \quad \text{and} \quad o_1 = 1, o_2 = 1, 2, \dots, 5, \quad (6)$$

where,  $n$  is the number of wavelet node,  $w_{jo}$  is the weight vector between product layer and the output layer,  $j$  is the number of wavelet node, and  $i$  is the number of joint.

Outputs are  $y^{o1} = \hat{X}$  and  $y^{o2} = \hat{Y}$ .

The weighting vector is as the follows:

$$\hat{X}(e|\hat{C}) = \hat{C} \Gamma \quad \hat{Y}(e|\hat{D}) = \hat{D} \Upsilon. \quad (7)$$

where,  $\Gamma = [y^{o1}_1, y^{o1}_2, \dots, y^{o1}_n]$  and  $\Upsilon = [y^{o2}_1, y^{o2}_2, \dots, y^{o2}_n]$

is output vector of wavelet function.  $\hat{C} = [w_{11} \ w_{21} \ \dots \ w_{n1}]^T$  and  $\hat{D} = [\omega_{11} \ \omega_{21} \ \dots \ \omega_{n1}]^T$  is weight vector which is trained by tuning algorithm. Optimal weight vector, which performs the perfect approximation, is as follows:

$$X^*(e|C^*) = C^* \Gamma \quad Y^*(e|D^*) = D^* \Upsilon. \quad (8)$$

### 3.2 WNNSMC

The control structure which is approximated by WNN is shown in Fig.3.

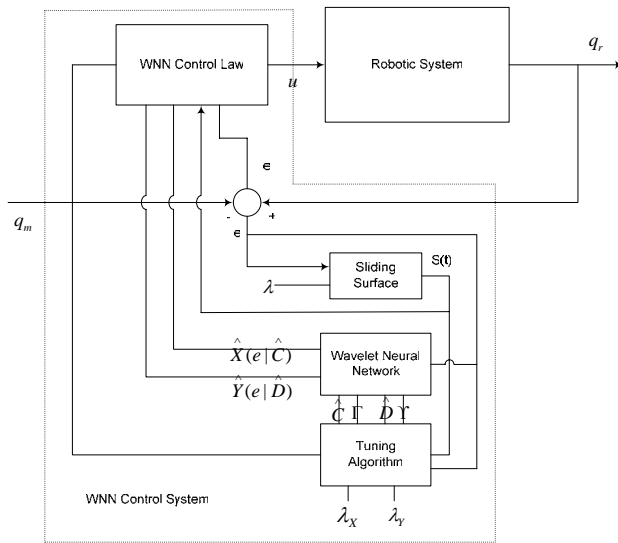

Fig. 3 WNNSMC scheme.

**Theorem 1:** Assume that the biped robot model (4) is used for our control system. The proposed control system is designed as (9). Then, the weights of the WNNs are trained by the adaptation laws (10)-(11), the stability of our control system is guaranteed.

$$\tau_i = -\hat{X}_i + \hat{Y}_i (\ddot{q}_{mi} - 2\lambda \dot{e}_i - \lambda^2 e) - \mu \text{sgn}(s_i) \quad (9)$$

$$\hat{C}_i = \lambda_x s_i \Gamma_i. \quad (10)$$

$$\hat{D}_i = \lambda_y s_i \Upsilon_i (\ddot{q}_m - 2\lambda \dot{e}_i - \lambda^2 e) \quad (11)$$

where  $\mu$  is a small positive constant, and  $\lambda_x$  and  $\lambda_y$  are positive tuning gains.

Proof: Lyapunov function candidate is as follows:

$$V(S, \tilde{C}, \tilde{D}) = \frac{1}{2} s^T \check{H} s + \frac{1}{2\lambda_x} \tilde{C}^T \tilde{C} + \frac{1}{2\lambda_y} \tilde{D}^T \tilde{D}, \quad (11)$$

where,  $\tilde{C} = C^* - \hat{C}$ ,  $\tilde{D} = D^* - \hat{D}$ . Taking the time derivative of the Lyapunov function, we obtain

$$\dot{V} = s^T \check{H} \dot{s} + \frac{1}{2} s^T \check{H} \dot{s} - \frac{1}{\lambda_x} \tilde{C}^T \dot{\tilde{C}} - \frac{1}{\lambda_y} \tilde{D}^T \dot{\tilde{D}}. \quad (12)$$

If we arrange (5) on  $\ddot{q}$ , then,

$$\ddot{q} = -H^{-1}B - H^{-1}G + H^{-1}\tau. \quad (13)$$

The sliding surfaces  $s$  are selected as

$$s = \dot{e} + 2\lambda e + \lambda^2 \int e. \quad (14)$$

Differentiating  $s$  with time and using (13), we obtain

$$\begin{aligned} \dot{s} &= \ddot{e} + 2\lambda \dot{e} + \lambda^2 e \\ &= \ddot{q}_r - \ddot{q}_m + 2\lambda \dot{e} + \lambda^2 e \\ &= -\ddot{q}_m - H^{-1}B - H^{-1}G + H^{-1}\tau + 2\lambda \dot{e} + \lambda^2 e \\ \dot{s} &= H^{-1} \left( -B - G + \tau + H(-\ddot{q}_m + 2\lambda \dot{e} + \lambda^2 e) \right). \end{aligned} \quad (15)$$

Lyapunov function can be summed as each sliding surface of joint angle. Therefore, we consider one joint to one stability decision. If every joint angle is stable, a biped system means stable. And we define  $W_{ci}$  and  $W_{di}$  as follows:

$$\begin{aligned} W_{ci} &= H_i \dot{s}_i = \left( -B_i - G_i + \tau_i + H_i(-\ddot{q}_{mi} + 2\lambda \dot{e}_i + \lambda^2 e_i) \right) \\ W_{di} &= \frac{1}{2} \dot{H}_i s_i. \end{aligned} \quad (16)$$

So,  $\dot{V}$  is represented as follows:

$$\begin{aligned} \dot{V} &= [s_1 \ s_2 \ s_3 \ s_4 \ s_5] \begin{bmatrix} W_{c1} \\ W_{c2} \\ W_{c3} \\ W_{c4} \\ W_{c5} \end{bmatrix} - [s_1 \ s_2 \ s_3 \ s_4 \ s_5] \begin{bmatrix} W_{d1} \\ W_{d2} \\ W_{d3} \\ W_{d4} \\ W_{d5} \end{bmatrix} \\ &= -\frac{1}{\lambda_x} \begin{bmatrix} \tilde{C}_1 \\ \tilde{C}_2 \\ \tilde{C}_3 \\ \tilde{C}_4 \\ \tilde{C}_5 \end{bmatrix} - \frac{1}{\lambda_y} \begin{bmatrix} \tilde{D}_1 \\ \tilde{D}_2 \\ \tilde{D}_3 \\ \tilde{D}_4 \\ \tilde{D}_5 \end{bmatrix} - \mu |s| \end{aligned} \quad (17)$$

and (17) is expressed as  $\dot{V} = \dot{V}_1 + \dot{V}_2 + \dot{V}_3 + \dot{V}_4 + \dot{V}_5$ .

First, if we consider ankle joint stability function  $V_1$  and substitute (7),  $X_i = -B_i - G_i + W_{ci}$ ,  $Y_i = H_i$ , and (9)-(10) into

$\dot{V}_1$ , we obtain  $\dot{V}_1$  as the follows:

$$\begin{aligned} \dot{V}_1 &= s_1 \left[ \tilde{C}_1^T \Gamma_1 - \tilde{D}_1^T \Upsilon_1 (\ddot{q}_{m1} - 2\lambda \dot{e}_1 - \lambda^2 e_1) - \mu \text{sgn}(s_1) \right] \\ &\quad - \frac{1}{\lambda_x} \tilde{C}_1^T \dot{\tilde{C}}_1 - \frac{1}{\lambda_y} \tilde{D}_1^T \dot{\tilde{D}}_1 \\ \dot{V}_1 &= -\mu_1 |s_1| + \tilde{C}_1^T (s_1 \Gamma_1 - \frac{1}{\lambda_{x1}} \dot{\tilde{C}}_1) \\ &\quad - \tilde{D}_1^T [s_1 \Upsilon_1 (\ddot{q}_m - 2\lambda \dot{e} - \lambda^2 e) - \frac{1}{\lambda_{y1}} \dot{\tilde{D}}_1] \end{aligned} \quad (18)$$

So,  $\mu |s_i| \leq 0$ .

Since  $\dot{V}_1 \leq 0$ ,  $\dot{V}_1$  is negative semi-definite. If  $\dot{V}_1$  is negative semi-definite, every stability function is negative semi-definite. Also, summation of  $\dot{V}_i$  is negative semi-definite.

Here,  $\tilde{C}$ ,  $\tilde{D}$  and  $s(t)$  are bounded. Let function

$$H(t) = \mu |s_1| + \mu |s_2| + \mu |s_3| + \mu |s_4| + \mu |s_5| = -\dot{V}(s(t), \tilde{C}, \tilde{D}) \quad (19)$$

Integrating  $H(t)$  on time, then we obtain

$$\int_0^t H(\rho) d\rho = V(s(0), \tilde{C}, \tilde{D}) - V(s(t), \tilde{C}, \tilde{D}) \quad (20)$$

Because  $V(s(0), \tilde{C}, \tilde{D})$  is bounded, and  $V(s(t), \tilde{C}, \tilde{D})$  is nonincreasing and bounded, the following result can be concluded

$$\lim_{t \rightarrow \infty} \int_0^t H(\rho) d\rho < \infty \quad (21)$$

Also,  $\dot{H}(t)$  is bounded. By Babalat's lemma, it can be  $\lim_{t \rightarrow \infty} H(t) = 0$ . That is,  $s(t) \rightarrow 0$  as  $t \rightarrow \infty$ . Consequently, the Lyapunov stability can be guaranteed. A respect of control input and tuning weight is as follows:

$$\tau = [\tau_1 \ \tau_2 \ \tau_3 \ \tau_4 \ \tau_5]^T$$

$$\hat{C} = [\hat{C}_1 \ \hat{C}_2 \ \hat{C}_3 \ \hat{C}_4 \ \hat{C}_5]^T, \ \hat{D} = [\hat{D}_1 \ \hat{D}_2 \ \hat{D}_3 \ \hat{D}_4 \ \hat{D}_5]^T$$

#### 4. SIMULATION

The 5-link biped model shown in Fig. 1 is used in simulation. The parameter of a biped robot is small sized, whose values are shown in Table 1. And desired references are a steady stable gait on horizontal plane.

Table 1 Parameters of biped robot.

Link	Mass $m_i$ (kg)	Moment of inertia $I_i$ (kg m)	Length $l_i$ (m)	Location of center of mass $d_i$ (m)
Torso	14.79	$3.30 \times 10^{-2}$	0.486	0.282
Thigh	5.28	$3.30 \times 10^{-2}$	0.302	0.236
Leg	2.23	$3.30 \times 10^{-2}$	0.332	0.189

The planning of the trajectory for a biped robot walking on a horizontal plane surface is divided into three parts: Starting step from the vertical position on a horizontal plane surface, steady walking on a horizontal plane surface and walking form start to steady on a horizontal plane surface. The locomotion mode of a biped robot on the horizontal surface has the form of Fig. 4. Reference trajectory for a steady stable walking is shown as Fig. 5.

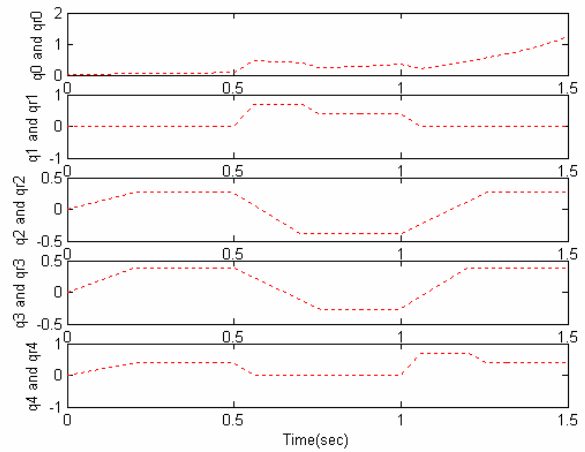

Fig. 4 Reference Trajectory of  $q$ .

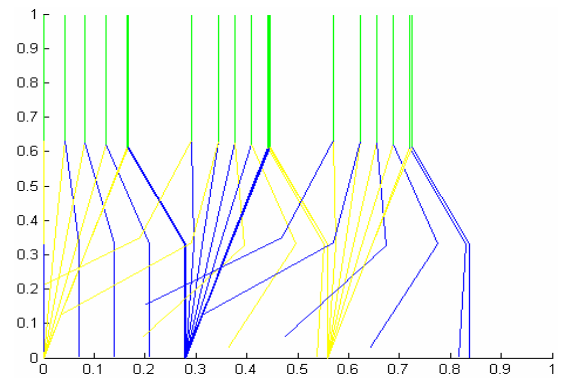

Fig. 5 Locomotion mode of 5-link biped robot.

#### 4.1. SMC

We design the SMC of a biped robot in accordance with [7]. We simulate SMC with 40% parametric uncertainty of which 40% each of parameter value add on mass and moment of inertia. We set up with control gain  $\lambda = 100$ . And we simulate in final time 1.5 sec and sampling time is chosen as 0.001 sec.

The SMC performs a robust and good performance in spite of uncertainties in simulation. Driving force and tracking error of SMC is shown in Fig. 7 and Fig.8, respectively.

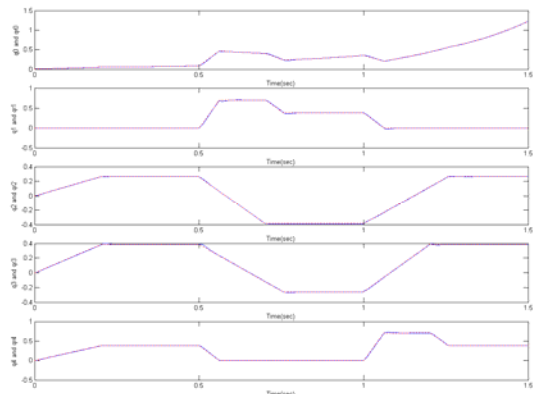

Fig. 6 Reference tracking trajectory for SMC.

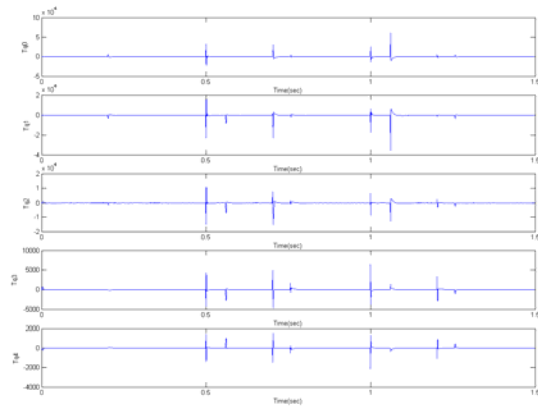

Fig. 7 Variation of the driving torques with time for SMC.

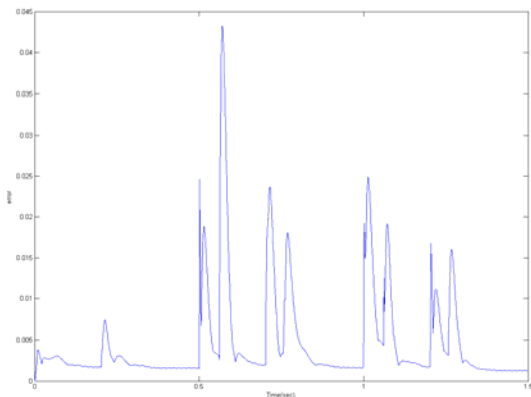

Fig. 8 Absolute summed error SMC in each joint for SMC.

4.2. WNNSMC

The SMC shows a robust and good performance. We verify that a proposed system which estimates uncertainties and nonlinearities is superior to the SMC by simulations. So we simulate under the same condition as the SMC with uncertainties in order to prove that a WNNSMC works well to estimate parametric bounds and performs robustly. The parameters of the WNNSMC are given as follows:

$$\lambda_X = 0.0000005, \lambda_Y = 0.0000003, \lambda = 100.$$

$\lambda_X, \lambda_Y$  of WNNSMC parameter are set up with the best performance through simulations. In each joint, Two WNNs are used as the estimator: one for estimating a function of gravity, Coriolis and disturbance, and the other for estimating a function of inertia matrix, where each WNN estimator has three wavelet nodes. Parameters of translation, dilation are randomly selected and weight is tuned by the Lyapunov stability synthesis. Also, we assumed that the biped robot has the 40% parametric uncertainty of inertia moment and mass.

Table 2 compares the performance of the WNNSMC with that of the SMC by means of the mean squared error(MSE). A biped robot tracking a reference trajectory is simulated without uncertainty and with uncertainty, respectively. By means of comparison of error, we can confirm that the WNNSMC is superior to the SMC for walking cycle without uncertainties as well as with uncertainties.

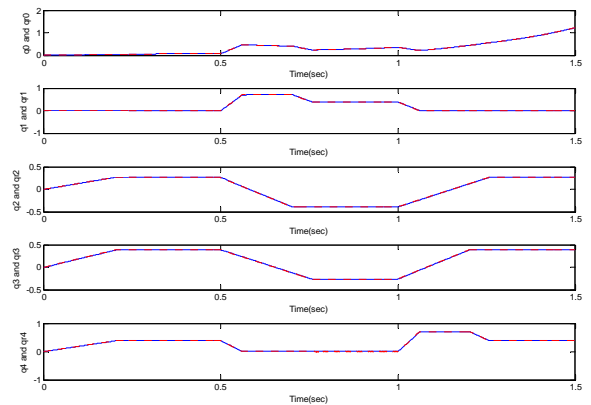

Fig. 9 Reference tracking trajectory for WNNSMC.

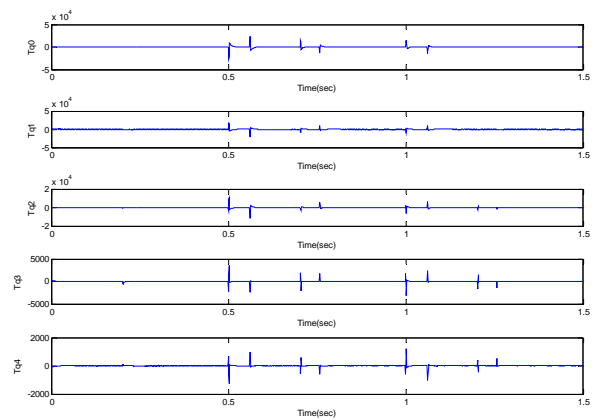

Fig.10 Variation of the driving torques with time for WNNSMC.

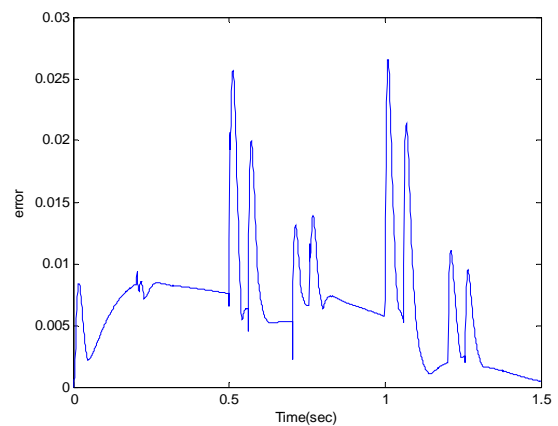

Fig.11 Absolute summed error of variation with time for WNNSMC.

Table 2 The performance comparison of SMC and WNNSMC.

Simulation Involvement	MSE of SMC	MSE of WNNSMC
No uncertainty	$3.1569 \times 10^{-5}$	$1.1744 \times 10^{-5}$
40% parametric uncertainty	$1.0991 \times 10^{-4}$	$6.6173 \times 10^{-5}$

## 5. CONCLUSION

In this paper, we designed a WNN control system based on sliding-mode technique for the 5-link biped robotic model in order to improve the efficiency of position tracking performance of biped locomotion. In our control system, WNN was employed to estimate uncertain and nonlinear functions of the 5-link biped robot. We designed two WNN estimators in each joint. The one is used to estimate a function of gravity, Coriolis and disturbance, and the other is to estimate a function of inertia matrix. Their weights were trained by the adaptation laws induced from the Lyapunov stability theorem, which guarantee the stability of the proposed control scheme. Through computer simulations, we confirmed that the performance of the WNNSMC was superior to that of the SMC regardless of uncertainties.

## REFERENCES

- [1] H. Hemami, C. Wil, and G. L. Goliday "The inverted pendulum and biped stability," *Math. Biosci.* Vol. 34 pp.93-108, 1977.
- [2] J. Furusho and I. Shinoyama, "Dynamic walk of a biped," *Int'l. Jour. Robotics Res.*, Vol. 3, No.2, pp. 60-74 1984.
- [3] H. Miura and M. Masubuchi, "Control of a dynamic biped locomotion system for steady walking," *ASME J. Dyn. Syst. Meas. Contr.*, Vol. 108, pp.111-118, 1986.
- [4] H. Miura and M. Masubuchi, "A theoretically motivated reduced-order model for the control of dynamic biped locomotion," *ASME J. Dyn. Syst. Meas. Contr.*, Vol. 109, pp. 155-163, 1987.
- [5] J. J. Slotine and W. Li, *Applied Nonlinear Control*, Prentice Hall, 1991.
- [6] K. J. Astrom and B. Wittenmark, *Adaptive Control*, Addison-Wesley, 1995.
- [7] S. Tzafestas, M. Raibert, C. Tzafestas, "Robust sliding-mode control applied to a 5-link biped robot," *Jour. of Intelligent and Robotic Systems*, Vol. 15, pp.67-133, 1966.
- [8] O. Omidvar and D. L. Elliott, *Neural Systems for Control* , Academic, 1997
- [9] J. R. Noriega and H. Wang, "A direct adaptive neural-network control for nonlinear systems and its application," *IEEE Trans. Neural Networks*, Vol. 9, No. 9, pp.27-34, 1998.
- [10] B. Delyon, A. Juditsky and A. Benveniste, "Accuracy analysis for wavelet approximations," *IEEE Trans. Neural Networks*, Vol. 6, No. 3, pp. 332-348, 1995.
- [11] Q. Zhang and A. Benveniste, "Wavelet networks," *IEEE Trans. Neural Network*, Vol. 3, pp. 990-898, 1992.
- [12] S. S. Ge, C. C. Hang, and T. Zhang, "Adaptive neural network control by state and output feedback," *IEEE Trans. Syst., Man, Cybern.*, Vol. 29, No. 12, pp. 818-828, 1999.