

Simple Dynamometer for Dynamics Investigation of Induction Motor

Tanin Inpradab, Sawai Pongswatd, Ruedee Masuchun, and Prapart Ukakimapurn

Department of Instrumentation Engineering, Faculty of Engineering, King Mongkut 's Institute of Technology Ladkrabang
Ladkrabang, Bangkok ,10520 Thailand
(Tel: 66-2-739-2406; Fax : 66-2-739-2407 ; E-mail: klsawai@kmitl.ac.th , E-mail : kook_tanin@yahoo.com)

Abstract: This paper presents a technique to evaluate torque and speed characteristics of induction motor with the Dynamometer. The simple Dynamometer controlled via microcontroller and displayed by computer. The Microcontroller generates the PWM (Pulse Width Modulation) signal and control the duty cycle of signal for control braking level. The Buck converter is a braking unit which uses IGBT as switch in circuit. The output current of the Buck converter and output voltage of tacho generator are converted to digital signals and analyzed by microcontroller. The signals are then sent to computer for displaying torque and speed responds independent on the braking time. The test results of the Dynamometer in this research can corectely predict the torque and speed response under reasonable tests. Moreover, this Dynamometer is easy and inexpensive to make.

Keywords: Dynamometer, PWM signal, Buck converter, Tacho generator

1. INTRODUCTION

At presents, electric motors are widely used in industries and daily life. However, its characteristics such as power, torque and speed of motor should be understood beforehand. There are several methods to evaluate the characteristics of motor such as calculating from equivalent circuit of motor or measuring a direct torque to plot graph from the measurable values at the various speed. Both methods mentioned above are inconvenient in term of use because it would take much time and many processes for testing. Thus, the paper presents an analytical technique to define the respond of speed and torque of the motor at various ranges. Dynamometer is applied as mechanical load for braking the motor under tests according to the specified range of control speed or torque of the motor. The braking rate is varied depending on the duty cycle of PWM signal. The PWM signal is generated from Microcontroller with control by computer.

2. THEORY AND PRINCIPLE

The simple Dynamometer uses a DC motor as a mechanical load. Buck Converter and Micro Controller are used to control rate speed or torque for braking design. The motor under test is coupling to DC motor, which supply the electrical power to Buck converter. The output voltage of Buck converter is controlled by PWM signal for control the braking rate. Software to calculate the duty cycle of PWM signal and display speed and torque response.

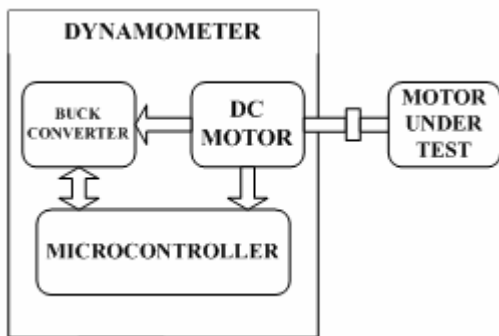

Figure 1. The structure of Dynamometer

Fig.1 shows structure of Dynamometer, which consisted essential part such DC motor are respond to be the duplicate

load by coupling method to fasten with shaft of motor under test.

2.1 DC motor

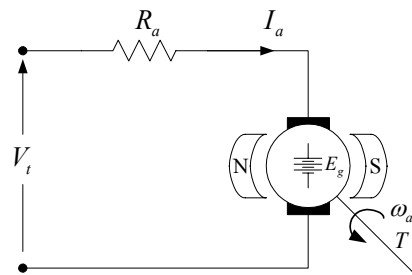

Figure 2. Equivalent circuit of Permanent magnet DC motor.

Equation of DC motor

$$V_t = I_a R_a + E_g \tag{1}$$

$$E_g = K_a \Phi \omega_a \tag{2}$$

$$T = K_a \Phi I_a \tag{3}$$

Equation of DC Generator

$$V_t = E_g - I_a R_a \tag{4}$$

$I_a R_a \ll E_g$ so that the V_t is approximated to E_g

$$V_t = E_g \tag{5}$$

When

$$V_t = \text{Input voltage (V)}$$

$$E_g = \text{emf voltage (V)}$$

$$I_a = \text{Armature current (A)}$$

$$R_a = \text{Resistance } (\Omega)$$

- K_a = Constant of motor
- ω_a = Speed of motor (Rad/S)
- Φ = Flux per pole (Wb)
- T = Torque of motor (Nm)

2.2 Buck Converter

The Buck Converter is a step down voltage converter. The Figure 3 shows block diagram of the Buck Converter, V_t, I_a from DC motor is converted to V_o, I_o dependent to Duty cycle.

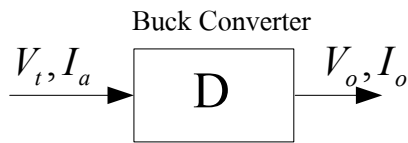

Figure 3. Block diagram of Buck Converter

The output voltage of Buck converter vary by Duty cycle of the PWM signal can be shown with equation (6).

$$V_o = D \cdot V_t \tag{6}$$

I_o, I_a and T can be calculated by equation (7),(8) and (9)

$$I_o = \frac{V_o}{R_L} \tag{7}$$

$$I_a = \frac{D \cdot V_o}{R_L} \tag{8}$$

$$T = KD V_o \tag{9}$$

When

- D = Duty Cycle of PWM Signal
- V_o = Output Voltage of Buck Converter (V)
- I_o = Output Current of Buck Converter(A)

3. DESIGNING AND CREATING DYNAMOMETER

This research conduct theory of DC machine for designing and creating Dynamometer. Microcontroller is a controller to generates PWM signal and calculates the speed and torque response. The system can be shown in Fig. 4.

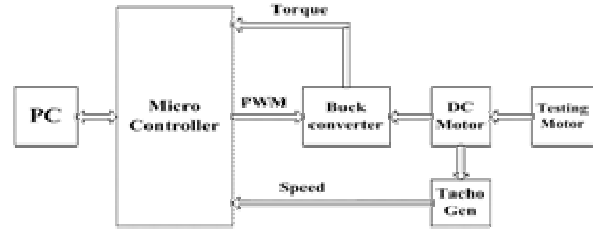

Figure 4 Block Diagram of Dynamometer

Fig. 4 shows flow chart of Dynamometer, torque response is measured from output current of Buck converter and speed is measured from output voltage of tacho generator. Both of values are analysis and codified with microcontroller and display by computer.

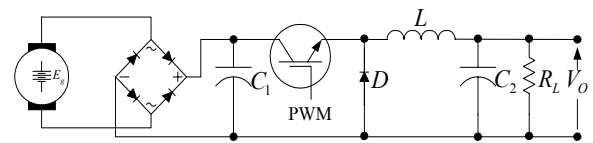

Figure 5. Buck converter circuit

Fig. 5 shows Buck converter circuit, which transfers energy from DC motor to resistor R_L independent to PWM signal. The value of resistor R_L and duty cycle of PWM signal to set the braking rate. PWM signal which controlled converter circuit and tune of duty cycle concerning with braking rate such duty cycle high the braking is fast. If the duty cycle operations are low, the braking is slow.

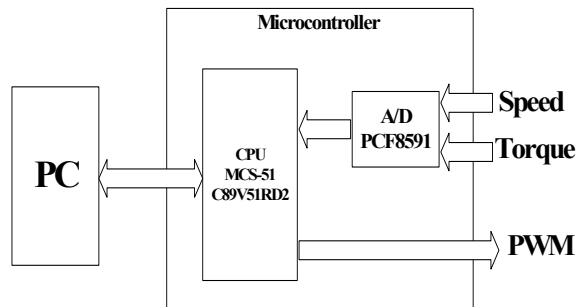

Figure 6 Microcontroller components.

Microcontroller board consists of C89V51RD2 and ADC PCF8591. C89V51RD2 is a CPU, which has a PWM module buildin on the chip. ADC PCF8591 uses to converts analog signals of speed and torque to digital signals. The both signal is calculated for control the braking and displaying. The software of the system for calculating the PWM signal and displaying the response can be shown in Fig. 7.

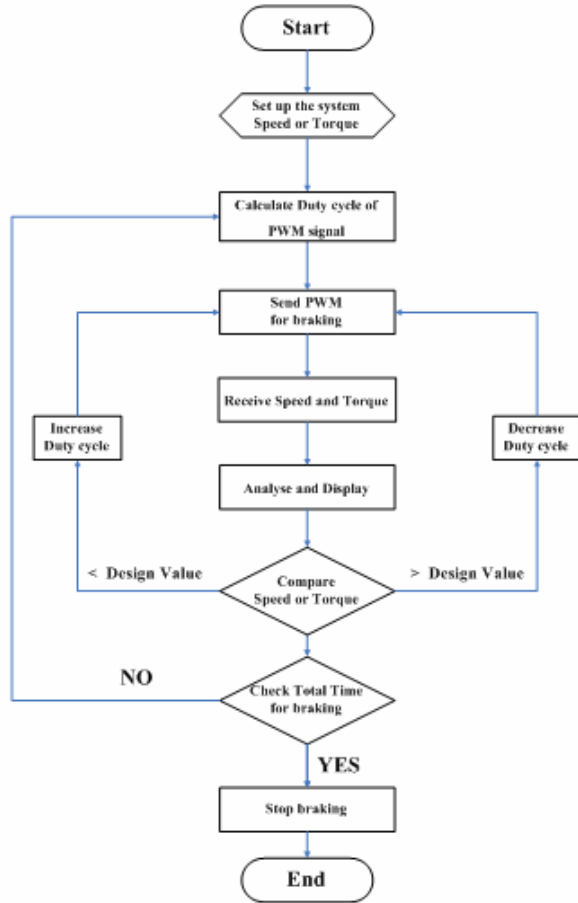

Figure 7 The flow chart of software operation

As scheme of Fig. 7, the flow chart displays software operations, start programs by indicated starting value of frequency and various port. Then beginning to testing by input set point value such starting speed braking, final speed braking, Sampling, and used duration when start to testing and figure out the interval of Pulse Signal and then send to buck converter circuit for control braking to receive torque and speed to displaying on monitor. Afterward the program comparing pwm signal value are sent to setting value until reach to set point value and then stop braking Dynamometer.

4. EXPERIMENTATION AND TESTING RESULTS

4.1 Experimentation

Dynamometer is connected by coupling with shaft of motor under test. This experiments use induction motor actuating 0.5 HP 3 phases 4 poles 220 volts 2 Amperes 1,400 rpm. Induction motor is driven with inverter.

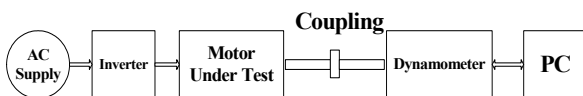

Figure 8. Block Diagram of the testing system

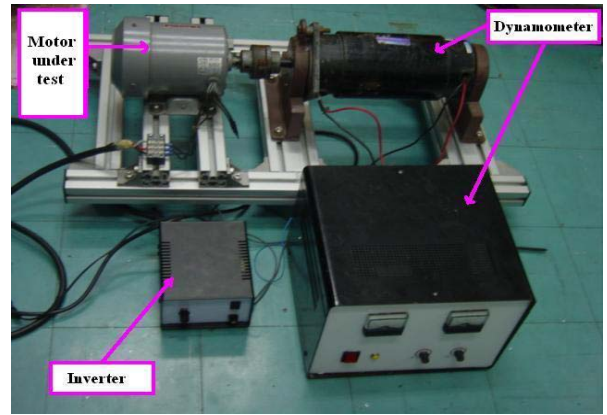

Figure 9. Overall System

Fig. 8 and Fig. 9 show block diagram and overall of system. The system can operate in manual mode and automatic mode with PC. The manual mode adjusts speed and torque for braking by volume and display with analog meter. Automatic mode uses a PC to set the speed or torque for braking and display speed or torque response in real time. Before uses the automatic mode, the software will be initial the value of braking time, Max. torque and Max. speed. The setting of automatic mode can be shown in the Fig. 10.

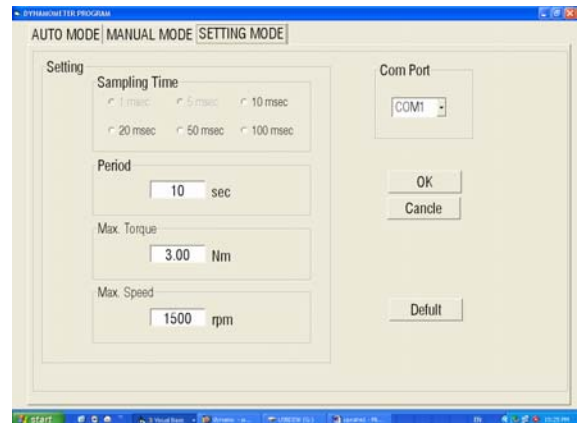

Figure 10 The setting mode display

4.2 Testing Result

Dynamic response of induction motor divides into speed response and torque response.

4.2.1 Speed responsive testing

Speed response testing, to set the speed of motor at 1,500 rpm and brakes to diminish of speed to 400 rpm. The response can be shown in Fig. 10.

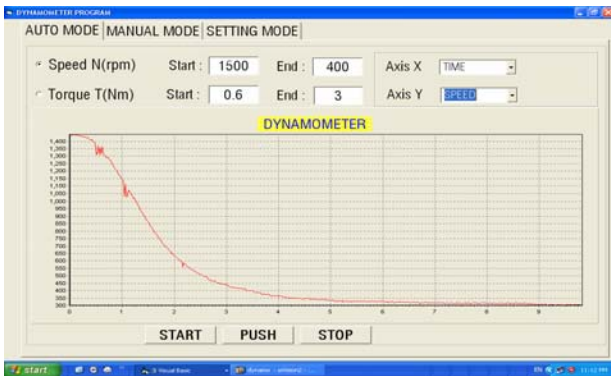

Figure 10. Speed response of induction motor

Fig. 10 shows speed response of induction motor that has a continue response by vary to the braking time. When start to braking speed value decrease from 1,500 rpm until to 400 rpm in 10 second.

4.2.2 Torque responsive testing.

Experiments to brake motor until value reach to the result as per experimentation 4.2.1 and record the value of speed as displaying on Fig. 11.

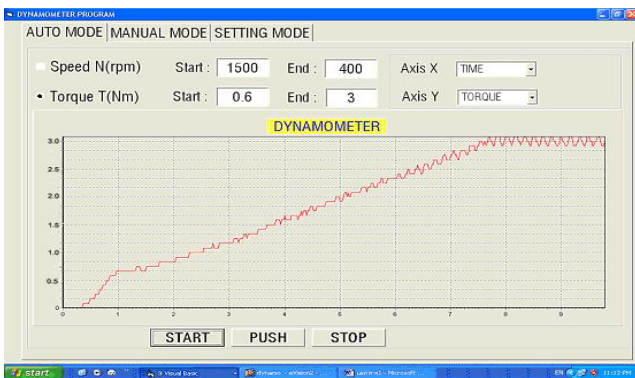

Figure 11. Torque response of induction motor

Fig. 11 shows Torque response of induction motor at various time. When start to braking torque value increase from 0.6 N-m to 3 N-m for final time by the relation of torque and braking time is continue response.

4.2.3. Torque and speed responsive testing.

The interval of torque and speed is respond are 1,500 - 400 rpm. As displaying on Fig. 12.

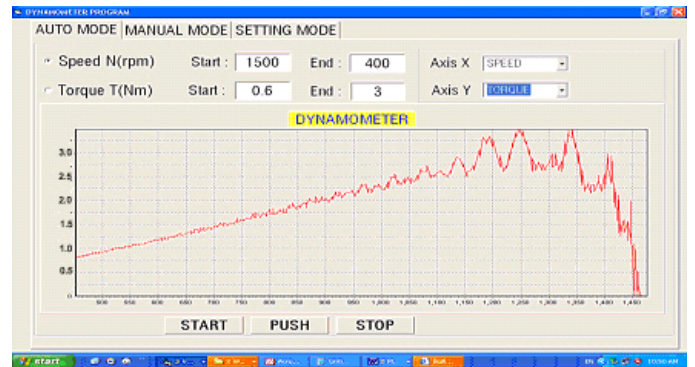

Figure 12. Torque and speed response

Torque and Speed respond testing shows both of Speed and Torque response of induction motor by braking duration. When start to braking speed value decrease but torque value increase to maximum torque, after that torque and speed value decrease continually. Torque and Speed is respond testing which shows has a similar shape to general speed and torque characteristic of induction motor.

CONCLUSION

The paper to designed Simple Dynamometer for evaluates speed characteristic basic and Torque of motor to study the result responding of speed and torque. The results of testing displaying the system of Dynamometer controller set are designed and able to works and satisfiable.

REFERENCES

- [1] IEEE Standard 112-2004 (Revision 1996) *IEEE Standard Test Procedure for Polyphase Induction Motors and Generator*, 2004.
- [2] Mohan, Undeland and Robbins, "Power Electronic", John Wiley and sons, 1995.
- [3] *Monographs in Electric Engineering*, Editors: P. Hammond and R.L. Grimsdale, 1986.
- [4] *Dynamic Simulation of Electric Machinery* / Chee-Mun Ong, 1998.
- [5] *Electronic Control of Switched Reluctance Machines*, Edited by T J E Miller, 2001.
- [6] *Principles of Electric Machines and Power Electronics*, Second Edition, P.C.SEN, 1997.