

Development of a Bluetooth Access Point for One-Phone System

Byungjo MIN*, June HWANG*, and Hagbae KIM*

* Department of Electrical and Electronic Engineering, Yonsei University, Seoul, Korea
(Tel : +82-2-2123-2778; E-mail: hbkim@yonsei.ac.kr)

Abstract: In this paper, we describe a development of a Bluetooth Access Point for the WAN connection of home network devices. Especially, users can access the PSTN at home instead of expensive digital cellular network through the AP, using the 'one-phone', which is the Bluetooth enabled cellular phone. The simultaneous benchmark test about telephone service and LAN access service shows the perfect compatibility and reasonable performance of the access point. The one-phone service can become a convergence of wired and wireless communication through the AP.

Keywords: Bluetooth, access point, home network, 3-in-1 phone, ubiquitous network, digital convergence

1. INTRODUCTION

Bluetooth is a universal radio interface in the 2.4GHz ISM-frequency band, which enables one to connect a wide range of small electronic devices easily and quickly, without the need for cables. The distinguishing key-features of Bluetooth are its minimal hardware dimensions, low complexity, low price and low power consumption [4]. The developed AP in this paper is used mainly for two purposes. One is for connecting a 3-in-1 phone in home network to PSTN (Public Switching Telephone Network) for voice communication. From now, we call the cellular phone including a Bluetooth CTP (Cordless Telephony Profile) as one-phone. The one-phone is a general cellular phone such as 2 or 3 generation CDMA phone including the Bluetooth core and CTP in its software stack and Bluetooth module chip in its hardware. We are provided the one-phones by the cell phone vendor. And then, we follow the standard of Bluetooth core and CTP in one-phone irrelatively to the hardware and other software specification of one-phone. The other purpose is for connecting the Bluetooth LAP (LAN Access Profile) terminals such as notebook PC or PDA to xDSL for data communication. There are some papers about the implementation using Bluetooth. However, the papers concerning Bluetooth AP mainly deal with only LAN access capability for data communication [1], [2]. Though [3] describes the performance of the AP regarding concurrent connectivity of voice and data, it has the limitation covering only ad-hoc manner. The developed AP, on the other hand, enables each Bluetooth terminals in home network to access the WAN composed of PSTN, xDSL using LAP and CTP. In other words, it covers not only ad-hoc manner but also infrastructured communication. Especially, users using one-phone at home can communicate with someone on external PSTN, having robust radio access surroundings and inexpensive service price with compared to digital cellular network via our AP. At the same time, users can download some files from the remote server to the notebook PC including LAP in its protocol stack by accessing xDSL. The one-phone service becomes a convergence of wired and wireless communication through the AP. Wireless communication means a digital cellular network such as CDMA or GSM out of door and wired one is PSTN at home. Fig.1 shows the Bluetooth network using the AP from home to out-of-door.

For this network structure, Korea Telecom (KT) commercializes the one-phone service. KT is a unique PSTN service provider in Korea. The APs are offered to the one-phone service users by KT. At home, users use their one-phones in a Bluetooth mode, instead of a general cellular

mode because of cheaper service cost. At that time, KT charges the users for the PSTN usages. As seen in Fig.1, the AP can be the core device of ubiquitous home network. In this paper, we implement the AP which is essential for the junction of mobile terminal and wired network and describe the hardware and software system of it. This paper is composed of 4 sections. The first one is the introduction. There is a topic about the development environment in the second section. The third one includes an implementation of Bluetooth core and profile stack on embedded system. In the fourth section, we describe whether the AP meets the specification of Bluetooth protocol and estimate the performance of the AP. Lastly, we conclude this paper in the section 5.

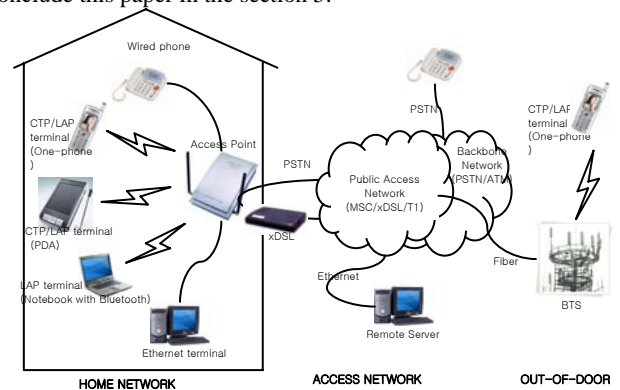

Fig. 1 One-phone service through the AP

2. DEVELOPMENT ENVIRONMENT

The AP is developed with using the IXP420 network processor based on the Intel XScale core. The Montavista Linux 3.0 is used as an operating system. After selecting the processor, we establish development environment of the embedded system suitable for the processor. Generally, we develop the kernel of the operating system, device drivers and applications on the host system and then, download them from the host system to the target system by using the network such as serial communication or TCP/IP. The Bluetooth module chip processes the data of the RF band and base band, and the remaining layers of protocol stack are processed on the host processor. The Bluetooth module chip is placed on the board. Two RJ-45 ports and two Ethernet MAC chips are placed on

the board for the LAN and WAN access. A UART Transceiver chip and a SP3232 are used for debugging during development, and a Loop trunk interface is adopted for the PSTN access. A 4 Mega byte flash memory and a 32 Mega byte SDRAM are added. Fig.2 shows the block diagram of designed AP hardware system.

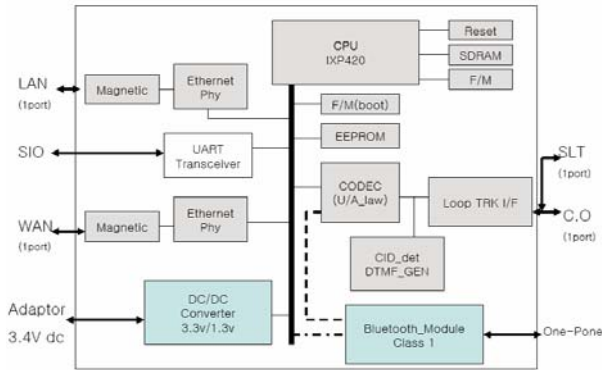

Fig. 2 Hardware architecture of the AP

3. SYSTEM DESIGN AND IMPLEMENTATION

We obey the standard specification of Bluetooth protocol. The AP in this paper plays a role like the master in case of piconet. Therefore, it can control the Bluetooth terminals which are on the active state up to 7 [5]. Moreover, there are LAP and CTP in the application profile stack to access the WAN. Fig.3 depicts the implemented Bluetooth protocol stack.

The Developed stack has a hierarchical structure. Core stack and the profiles are placed such as Fig.3 [5] [6]. Data on the RF band and the base band are processed in the Bluetooth module chip. Upper core and profile layer are processed on the processor of the AP. Link manager and Bluetooth core stack modules operate on the Linux kernel level. The upper layer, profiles operate on the user level. The AP needs multiprocessing for the channel assignments, the management of slaves and the link controls. At that time, for more active and faster application responses, the AP assigns and frees the memory in the kernel level and launches 7 kernel threads simultaneously when the system starts. Like a general Linux's operation, the system calls are used to communicate between core stack in the kernel level and profile stack in the user level [7] [8]. Our AP processes the Synchronous Connection Oriented (SCO) link and the Asynchronous Connectionless (ACL) link at the same time because CTP and LAP may operate simultaneously. Fig.4 shows the appearance of a developed AP board. There are two Ethernet ports for the access of LAN/WAN, two connectors for the access of common wired telephone at home and the external PSTN, a serial cable connector in the board. The network processor for data processing is placed in the middle of the board and the Bluetooth module chip is placed near the antenna connector.

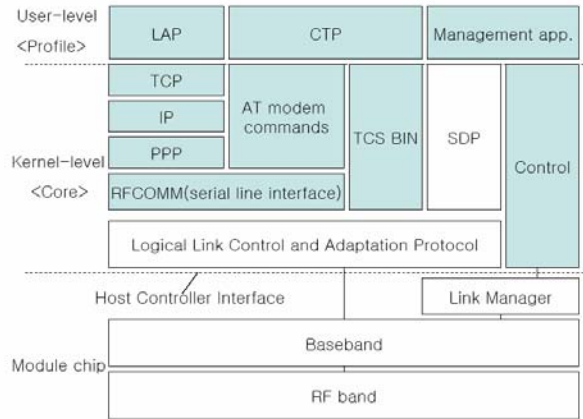

Fig. 3 Structure of Bluetooth protocol stack in the AP

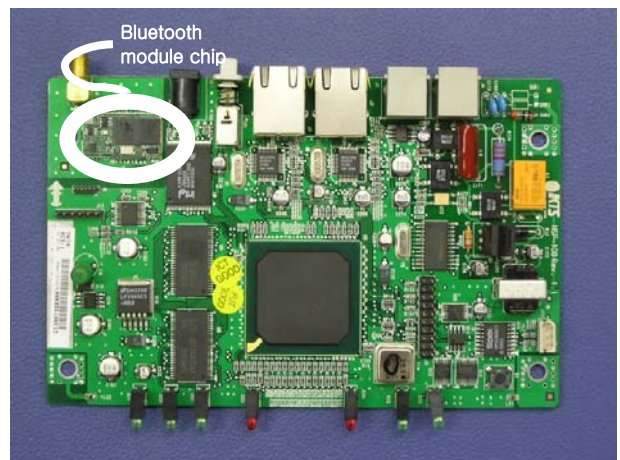

Fig. 4 The appearance of the AP on the dedicated board

4. PERFORMANCE EVALUATION AND ANALYSIS

We conduct the test for the channel usage of CTP and LAP terminals to evaluate the performance of the AP. A notebook PC is selected for the LAP terminal and Bluetooth USB dongle is attached to this as the Bluetooth chip module. The driver of the USB dongle is the WIDCOMM's protocol stack authenticated globally [11]. The prototype of the one-phone is used for the CTP terminal. The test environment is shown in Fig.5. We record the throughput and the requests per second processed by the remote HTTP server for two cases. One case is that just one LAP terminal becomes the HTTP client for the remote server in WAN via the AP. The other case is that one LAP terminal also becomes the HTTP client for the remote server in WAN while one CTP terminal is communicating to other PSTN telephone in WAN through the AP. The specification of notebook PC used as the LAP terminal is Intel Celeron 795MHz CPU and 384MB RAM. The specification of remote server is AMD 1.1 GHz CPU and 516MB RAM. The web server program is Apache 1.3.31 for Windows and the benchmarking tool is ZDnet's WebBench 4.1. The LAP terminal requests the test suite file described in Table 1 from

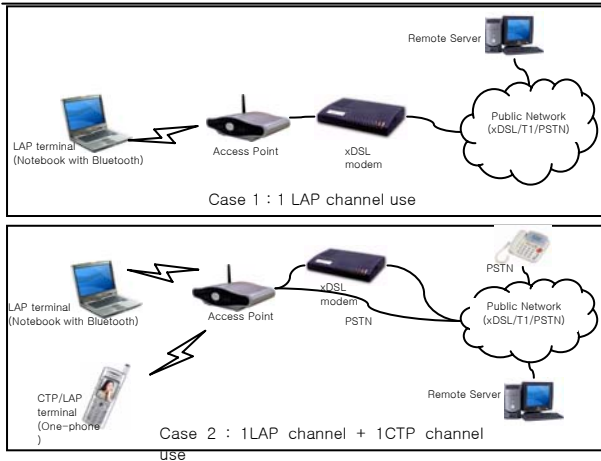

Fig. 5 Performance evaluation of the AP for two cases

the remote server. In the table, file size is byte unit and the classes of files are confined to gif or htm for the static web service.

In each case, the throughput and the requests per second of LAP terminal are shown in Fig.6. Bluetooth radio part uses the Frequency Hopping Spread Spectrum (FHSS) [10] and base band part uses a Time-Division Duplex (TDD) scheme. A slotted channel is applied with a nominal slot length of 625 μ s. On the channel, information is exchanged through the packets. Each packet is transmitted on a different hop frequency. A packet nominally covers a single slot, but can be extended to cover up to five slots according to the type of packet. The even slot is used by the AP and the odd one is used by slaves in round-robin manner. The Bluetooth protocol uses a combination of the circuit and packet switching. The LAP terminal uses SCO link and the CTP terminal uses ACL link. Each SCO link has to carry the voice at 64kbit/s. For this type of link, the master reserves two consecutive slots (forward and return slots) at fixed intervals. In this test, SCO link packet is the type of HV3 [5] since we assume that the radio communication between the AP and the one-phone is under the best condition. This type of packet has the length of 30byte. To meet the 64kbit/s condition, about 273 packets of HV3 have to be exchanged within 1 second. There are 1600 slots in a second. Therefore, every 5th slots are reserved for SCO link. In the first case of our test, the LAP terminal uses every slots without any interference. In the second case, the CTP terminal is added to preempt the every fifth slots. The channel occupancy time of the LAP terminal in the second case is reduced by 20% apparently compared to the occupancy time of the first case. Therefore, the throughput of the second case has to decrease for those of the first case by 20%. From the Fig.6, we can find out that the above analysis is valid. However, the value of the requests/sec doesn't have a linear relation with the throughput. In other words, the amount of data processed by the web server doesn't have the linear relation with the number of processed files. As you see the

Table 1, the file sizes of the test suites are dramatically different each other. Even the maximum file size (22132bytes) is bigger than the throughput of the second case. Moreover, the order of requested files is random on WebBench policy. Therefore, as the test suites changes, the number of the requests/sec changes. In detail, according as how big file is requested, how many times the file is requested during the benchmark time and how long the benchmark time is taken, the value of the requests/sec moves within narrow limits and we cannot predict the exact requests/sec. If we conduct the benchmark with infinite operating time, we will see that the mean value of the requests/sec is decreased by about 20% for the first case. We can conclude that the throughput shows the right result and the value of the requests/sec is roughly tracing the tendency of the throughput. However, more detailed analysis about the HTTP protocol modeling is going to be thought as the future work. In this paper, we focus just on whether our AP is compatible with other company's Bluetooth hardware and software or not. This compatibility and the analysis of the throughput decrease prove that our AP is implemented with completely satisfying the specification of the Bluetooth protocol.

Table 1 Test suite of WebBench for HTTP

Filename	Distribution (%)	Actual (%)
Class_223.gif	20	18.97
Class_735.gif	8	7.93
Class_1522.gif	12	13.1
Class_2895.gif	20	18.97
Class_6040.gif	15	18.28
Class_11426.gif	17	15.86
Class_22132.gif	7	5.86
Class_fractional	1	1.03

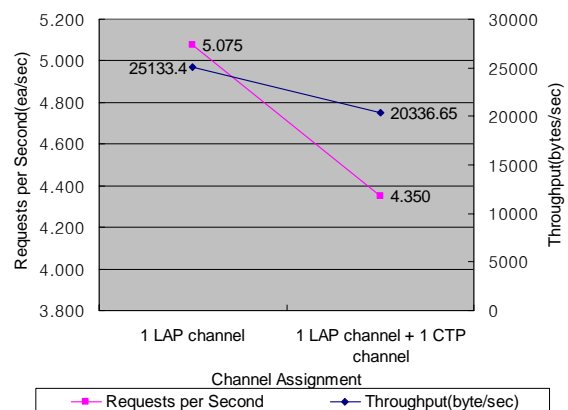

Fig. 6 Throughput and requests per second on 2 cases

5. CONCLUSION

We developed the AP. Users can connect the access network with the Bluetooth terminals via this device. With one-phone, we can connect the digital cellular network outside

and exchange the voice and the data by connecting the PSTN at home through the AP. We tested the compatibility with other vendor's Bluetooth module and the results show that our AP is implemented based on the specification of Bluetooth protocol stack and has a good performance. The AP makes the one-phone digital convergence device combining wireless and wired network. The AP can be the core device in Bluetooth home network.

REFERENCES

- [1] S.-Y. Chiu, H.-P. Chang, and R.-C. Chang, "Providing mobile LAN access capability for Bluetooth devices," *Parallel and Distributed Systems, Proceedings. Ninth International Conference on*, pp.631-636, 2002
- [2] Y. Lim, J. Kim, S. Min, and J. Ma, "Performance evaluation of the Bluetooth-based public Internet access point," *Information Networking Proceedings. 15th International Conference on*, pp.643 - 648
- [3] A. Dahlberg, H.-J. Zepernick, G. Mercankosk, and M. Fiedler, "Multi AP strategies for SCO traffic in a Bluetooth based wireless LAN," *Vehicular Technology Conference., The 57th IEEE Semiannual*, vol. 2, pp.970 - 974, 2003
- [4] R. Kapoor, L.-J. Chen, Y.-Z. Lee, and M. Gerla, "Bluetooth: carrying voice over ACL links," *Mobile and Wireless Communications Network, 4th International Workshop on*, 9-11, pp.379 - 383, Sept. 2002
- [5] Bluetooth SIG, Specification of the Bluetooth System core, 2001
- [6] Bluetooth SIG, Specification of the Bluetooth System profile, 2001
- [7] P. Bovet and M. Cesati, "Understanding the LINUX KERNEL second edition," O'reilly 2003
- [8] S. Jochen, "Mobile Communications second edition," Addison- Wesley 2003
- [9] W. Simpson, "The Point-to-Point Protocol(PPP)," STD 50, RFC 1661, July 1994.
- [10] J. Haartsen, "The bluetooth radio system," *IEEE Personal Communications*, vol. 7, pp. 28-36, Feb. 2000.
- [11] www.widcom.com