

User Interface in Web Based Communication for Internet Robot Control

Masanori Sugisaka^{1,2}, and Desa Hazry¹

¹ Department of Electrical and Electronics Engineering, Oita University, Oita 870-1192, Japan
(Tel : +81-97-554-7831)

² The Institute of Physical and Chemical Research (RIKEN) at Nagoya, Anagahora, Shimoshidami,
Moriyama-ku, Nagoya, 463-0003, Japan
(Tel : +81-97-554-7841)

E-mail: msugi@cc.oita-u.ac.jp hazry_desa@cc.oita-u.ac.jp

Abstract: Robot control involves advance programming, scientific and high technology. The systematic and methodological aspects of robot controls often results in having superficial control design problems that can negatively affect the robot application, usability and appeal. User friendly interface of robot control is extremely advantageous and more attractive. To illustrate, the application of medical robot is usually handled by clients who have little background in advance programming language. Thus, it would be difficult if the client needs to use programming language to control the robot. It would justify better if the robot control is presented in a meaningful interface to the client. This way the robot application would be more natural and user friendly.

This paper describes the method of developing the user interface for web based communication to control an internet robot named Tarou. The web based communication tasks involves three levels. The first one accommodates on the client sending commands to robot through the internet. The next communication level relates to the robot receiving the commands sent by the client. The final communication level generates on sending feedback on status of commands by the robot to the client. The methodology used here can be elaborated in four hierarchical steps; identify user needs and robot tasks, identify the enhancing tag reference used by the server, induce the tag into HTML, present the HTML in attractive user interface as the client control panel.

Keywords: Web Communication, internet, user interface.

1. INTRODUCTION

User friendly interface of the robots control is extremely advantageous and more attractive. It would justify better if the robot control is presented in a meaningful interface to the client. This way the robot application would be more natural and user friendly [1], [2], [3] and [4]. This paper describes the experiment method of developing the user interface for web based communication to control an internet robot named Tarou.

This method is developed using combination of web technologies which are web browser, socket communication, Visual C++ language, HTML and Remote Data Inspection System (RDIS) server.

The web based communication architecture involves three levels. The first one accommodates on the client sending commands to robot through the internet. The next communication level relates to the robot receiving the commands sent by the client. The final communication level generates on sending feedback on status of commands by the robot to the client.

The methodology used here can be elaborated in four hierarchical steps:

- identify user needs and robot tasks,
- identify the enhancing tag reference used by the server,
- induce the tag into HTML,
- present the HTML in attractive user interface as the client control panel.

2. THE WEB TECHNOLOGIES

2.1 The Web Application

Windows based standard application is being used. The web browser, Explorer or Netscape is used for the user interface to access to the internet controlling the robot.

2.2 The Socket Communication

The communication between two computers, both visual processing computers and controlling hardware computers are govern by implemented Transmission Control Protocol/ Internet Protocol (TCP/IP) socket. In one robot control system, we often create one virtual channel between the web server and the robot server [5]. The virtual channel is used to transmit images, data and commands. The web server receives the client's command through the internet and then sends it to the robot server. The robot server transmits images and environmental condition (such as sensor data) to the client user.

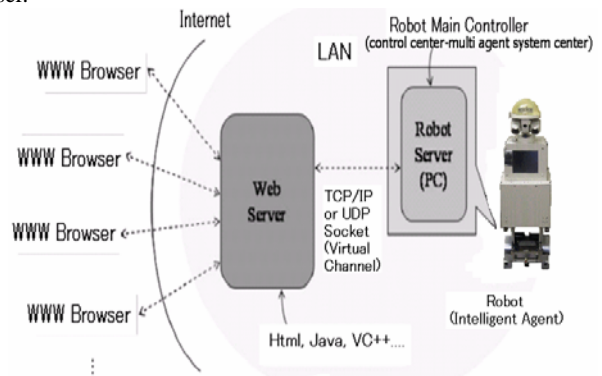

Fig. 1 Communication Software Structure.

2.3 Programming Language

Visual C++ language is a combination of procedural programming and Object Oriented programming. It has useful features for data hiding, encapsulation, templates and exception handling. More room for future experiment development.

HTML – Hypertext Markup language popular and highly used simple descriptive. It can be constructed in Microsoft word document, which is highly available in most PC and Workstation. It integrates text, colors, graphics, animations,

sound and video in a web browser. Highly useful features are to develop attractive and user-friendly interface.

2.4 Remote Data Inspection System (RDIS/LT)

The remote control equipment used in Tarou is transmitter/receiver RDIS/LT-08 which has 8 input ports, 8 output ports and RS232 port. 8 output ports of RDIS/LT are connected to 8 input ports of the I/O board, IBX-2726C in the computer of Tarou. The 8 input ports of RDIS/LT are connected to the corresponding ports to check the status of the hardware equipments.

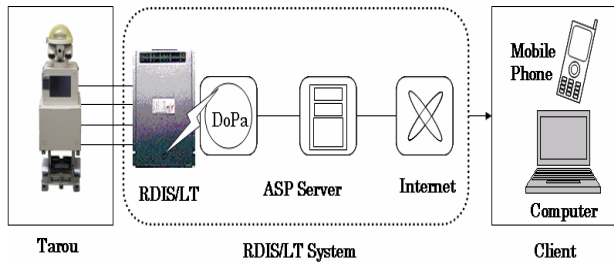

Fig. 2 Remote Control of Tarou.

2.5 The robot Tarou

The robot has two driving wheels. Both are on the left and right sides of the robot and two castor wheels to support the body. Driving wheels are driven by Direct Current (DC) motors controlled via I/O card, Digital/Analog converters, and Pulse Width Modulation (PWM) controllers. Relative motion and angular speed can be determined with the use of wheel encoders. The robot has a rotating head.

For the head positioning a stepper motor is used. There are two color Charge Coupled Device (CCD) cameras mounted on the robot head. Zoom, pan and tilt values of these cameras are set from the PC serial port using the SONY VISCA protocol. Video images are acquired via standard video capture card. Additionally the robot has six ultrasonic sensors, 4 Light Emitting Diodes (status LEDs) touch panel, keyboard, speakers and microphones.

3. WEB BASE COMMUNICATION ARCHITECTURE

The client sends commands to robot through the internet. The robot receives the commands sent by the client. The robot sent feedback on status of commands to the client. Underlying coding tag transmitted by the server to robot trigger the Visual C++.

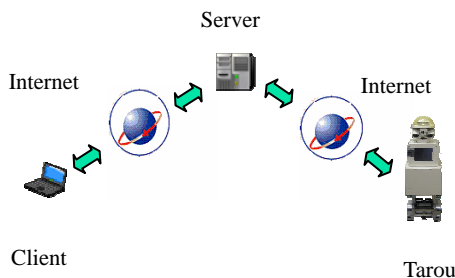

Fig. 3 Diagram with all hardware in place, the communication flow.

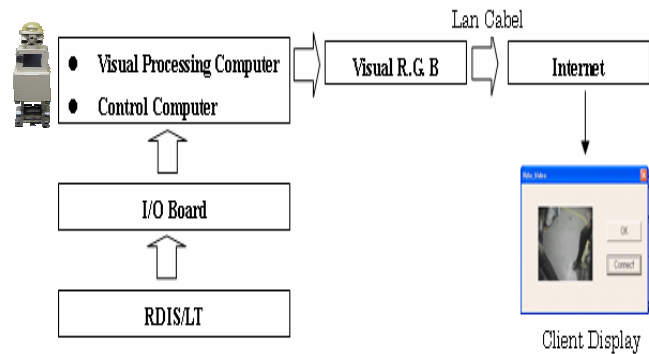

Fig. 4 Communication flow.

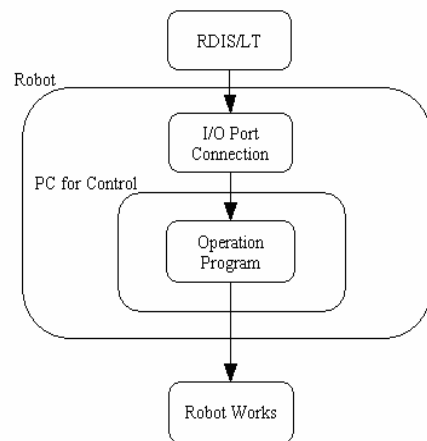

Fig. 5 System Architecture.

4. THE EXPERIMENT METHODOLOGY

The methodology used here can be elaborated in four hierarchical steps. The first step involves determining the user needs and robot tasks. This experiment is a preliminary experiment and the first step of many experiment series to come. At this stage, the robot is developed to perform basic movements. The identified basic movements are moving forward, moving back, moving right, moving left and stop. Eye movements involve the robot to look in front, up and down. Head movements are center, left and right. Another experiment [6] includes visual function in the web control panel, but the problem is on time delay [7], [8] and [9].

After determining the user needs, the server tag is identified. Tag is the command words used by the server. The out signal from RDIS/LT has been prescribed [10] and these output signal triggers the signal number which determined the Tarou's action programs. The tag is used to trigger the output signals from RDIS/LT. The tag identified is related to executable scripts. This tag is then induced in HTML programming as below.

```
<td>
```

```
<!--IRMEXde"output3"";:arrw06_14c.gif:left:"-->
```

```
</td>
```

HTML Programming with Tag induced.

<td> and </td> is part of the HTML programming .

!--IRMEXde.....is the tag name followed by the arguments.

"output3" is the tag argument 1.

";arrw06_14c.gif:left;" is the tag argument 2.

The HTML program is then written to produce a user friendly interface panel which can be used as the client control panel. Text, colors, graphics, animations, sound and video can be integrated in the client interface panel which can be accessed through the web browser. The user interface developed in this experiment uses symbols and words as illustrated in figure 6.

All figures and tables should be placed after their first mention in the text. Large figures and tables may span across both columns. Scanned images (e.g., line art, photos) can be used if the output resolution is at least 600 dpi.

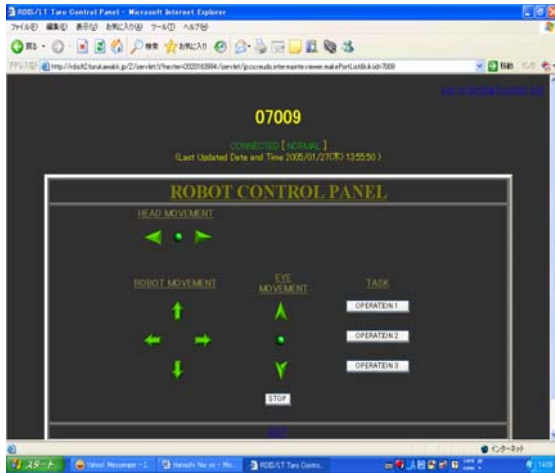

Fig. 6 A Sample of Tarou's Web Control Panel.

Output Signal from RDIS/LT				Event of Tittle	Tarou's Action Programs
5	6	7	8		
0	0	0	0	output1	Stop moving
0	0	0	1	output2	Initialization
0	0	1	0	output3	Turn the head to the left
0	0	1	1	output4	Turn the head to the right
0	1	0	0	output5	Turn the head to the front
0	1	0	1	output6	Turn the CCD camera up
0	1	1	0	output7	Turn the CCD camera down
0	1	1	1	output8	Turn the CCD camera forward
1	0	0	0	output9	Land mark recognition
1	0	0	1	output10	Tarou move forward
1	0	1	0	output11	Tarou move backward
1	0	1	1	output12	Tarou turn left
1	1	0	0	output13	Tarou turn right
1	1	0	1	output14	Line tracking
1	1	1	0	output15	Face tracking and recogniton
1	1	1	1	output16	End the programme

Fig. 7 RDIS/LT output signal and Tarou's action programs.

5. CONCLUSIONS

In this paper, a framework of human interface system for teleoperation of mobile robot was discussed. The prototype of the teleoperation system was constructed utilizing the WWW system as a development environment. With the user friendly interface, robot control is extremely advantageous and more attractive and the application would be more natural and easy

to understand even by client who have a little background in advance programming.

REFERENCES

- [1] Hironori Hiraishi, Hayato Ohwada and Fumio Mizoguchi, "Web-based Communication and Control for Multiagent Robots," *Proc. of the IEEE/RSJ, Intl. Conference on Intelligent Robots and Systems*, Victoria, B.C., Canada, October 1998
- [2] Tsuyoshi Suzuki, Teruo Fujii, Kazutaka Yokota, Hajime Asama, Hayato Kaetsu and Isao Endo, "Teleoperation of Multiple Robots through the Internet," *5th IEEE International Workshop on Robot and Human Communication*, pp. 84-89 Nov 1996.
- [3] Eric Paulos and John Canny, "Delivering Real Reality to the World Wide Web via Telerobotics," *Proc. of the IEEE, International Conference on Robotics and Automation*, Minneapolis Minnesota, Vol. 2 , 22-28 April, pp. 1694-1699, 1996
- [4] A. S. Sekmen, Z. Bingul, V. Hombal and S. Zein-Sabatto, "Human-Robot Interaction Over The Internet," *Proc. of the IEEE, Southeastcon 2000*, 7-9 April, pp.223-228, 2000
- [5] Ren C. Luo, Kuo L. Su, Shen H. Shen and Kuo H. Tsai, "Network Intelligent Robots Through the Internet: Issues and Opportunities," *Proc. of the IEEE*, Vol.91, No.3, March 2003
- [6] Jiwu Wang and Masanori Sugisaka, "How to make a mobile robot move more reliably?," *Proc. Of The 10th Int. Symp. On Artificial Life and Robotics (AROB '05)*, Beepu, Oita, Japan, Feb 2005
- [7] J. Kikuchi, K. Takeo, and K. Kosuge, "Teleoperation System via Computer Network for Dynamic Environment," *Proc. IEEE Int. Conf. Robotics and Automation*, Leuven Belgium, pp. 3534-3539, May 1998.
- [8] X. Huo and J. Su, "New Approaches to Internet Based Intelligent Robotic System," *Proc. IEEE Int. Conf. Robotics and Automation*, New Orleans LA, pp.3363-3368, April 2004.
- [9] X. Huo and J. Su, "A Distributed Architecture for Internet Robot," *Proc. IEEE Int. Conf. Robotics and Automation*, New Orleans LA, pp.3357-3362 April 2004.
- [10] M. Sugisaka and M. R. M Johari, "Remote Control of Autonomous Robot via Internet," *ICCAS 2004*, Bangkok Thailand, August 2004.