

# Development of the Pulsed Plasma Thruster (PPT) for Science and Technology Satellite-2 (STSAT-2)

G.-H. Shin\*, M.-R. Nam\*, W.-H Cha\* and J.-T. Lim\*

\*Satellite Technology Research Center, Korea Advanced Institute of Science and Technology, 305-701, Korea.  
(Tel: +82-42-869-8636; Fax: +82-42-861-0064; Email:ghshin@satrec.kaist.ac.kr)

**Abstract:** This paper describes an engineering model development of a pulsed plasma thruster, which is capable of an impulse bit of 20uNs and a specific impulse of 800s. The solid fuel which is Teflon allows for a self-contained, inert and stable propellant system. And, the PPT technology makes it possible to consider a revolutionary attitude control system (ACS) concept providing stabilization and pointing accuracies previously obtainable only with reaction wheels, with reduced mass and power requirements.

**Keywords:** Pulsed Plasma Thruster, Engineering Model, Science and Technology Satellite-2, Attitude Control System

## 1. Introduction

This paper describes an engineering model development of a pulsed plasma thruster, which is capable of an impulse bit of 20uNs and a specific impulse of 800s. An engineering model PPT for STSAT-2 was designed for attitude control and momentum unloading. The number of PPTs in STSAT-2 is only one, and the attitude of STSAT-2 is mainly controlled by reaction wheel assemblies (RWAs), the magnitude of Moment of Inertia (MOI) using them depends on the number of turns of RWAs, and takes effect to the center of mass. The most important thing in the satellite development is dry mass and power consumption because of a limited resource in the space. RWAs have such a disadvantage in dry

+1500V. And its electrical energy is charged in capacitor bank within the specified time of 20ms. The propellant used for the PPT in STSAT-2 is Teflon, which is made of TPFE. The performance of the PPT is that the specific impulse and the impulse bit are 800s and 20uNs, respectively. Compared to a chemical propulsion system, the impulse bit for electrical thruster including STSAT-2 PPT is too low, but it means that precise attitude control is available for satellite. In addition to the impulse bit, the specific impulse is higher than the chemical propulsion system, it means the efficiency of propellant used for the PPT is more higher than the chemical propulsion system, on the other hands, the life time is longer than chemical ones. Due to its efficient fuel consumption and low power requirements, the PPT for STSAT-2 can enhance its attitude and maneuvering capabilities.

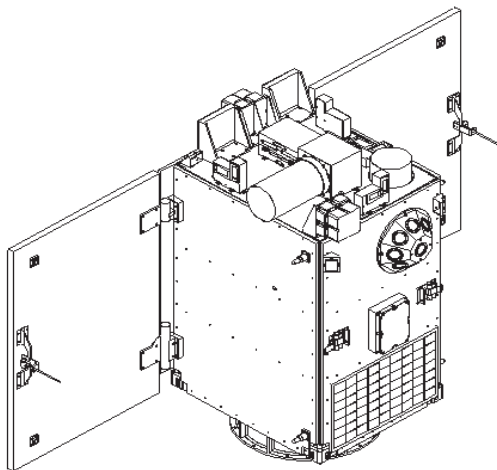

Fig. 1. The Overall STSAT-2

mass and power consumption that the PPT is mainly focused on main theme in the field of satellite attitude control. The PPT in STSAT-2, consisting of power processing unit (PPU), capacitor bank which is around 2uF and head which produces thruster and consists of feeding spring and nozzle, is currently developed in satellite technology research center (SaTReC) with +28V power source. Normally, the power source of satellite comes from the solar flux in the space and the solar flux is converted into the electrical energy around +28V, then it goes to PPU to generate a high voltage around

## 2. Attitude Control Systems

General speaking, the subsystems for satellite attitude control mainly consists of sensors and actuators. Firstly, there are four types of sensor such as star sensor, Earth sensor, Sun sensor, Earth horizon sensor and magnetic sensor form Earth also including gyro. Secondly, the actuators will include reaction wheel assembly, magnetic torque bar, boom deployment and pulsed plasma thruster as shown figure 2 given below.

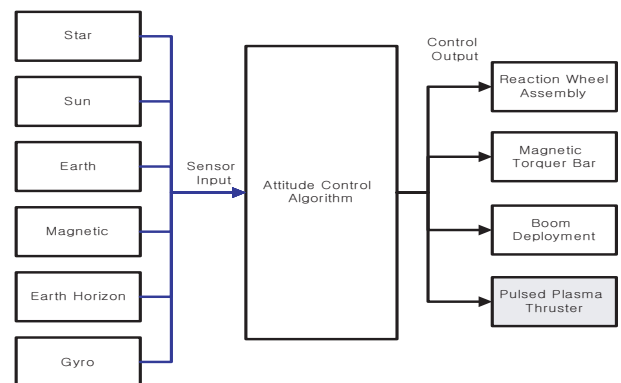

Fig. 2. Configuration of Attitude Control

As you imagined, one of the actuators is the pulsed plasma

thruster which is the part of actuator.

### 3. Pulsed Plasma Thruster

#### 3.1. Power Processing Unit

As mentioned in the previous section, PPU stands for the power processing unit which is generating electrical power to initiate plasma in the vacuum with Teflon. To initiate plasma, the required power for PPT is around +1500V in case of STSAT-2.

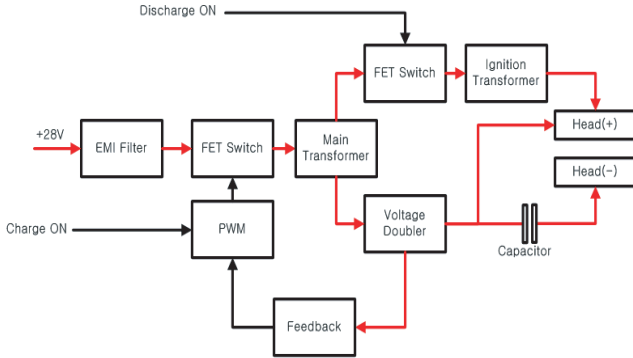

Fig. 3. Configuration of PPU

From figure 3, +28V power from the electrical power subsystem is generated and goes to the PPU to produce an appropriate power for PPT around +1500V. The PPU is equipped with pulse width modulator which modulates a signal depending on the width to make high voltage by using transformer and voltage doubler circuits. Unless we design the PPT with voltage doubler circuits, the power transformer is much more bigger than those of doubler circuits. Normally, the smaller we design electrical board, the more benefit the PPT has reliability in case of satellite. We can also see an ignition circuit to initiate plasma between electrodes. Upon the command from the command processing unit such as TCU in figure 2, the igniter responds to it.

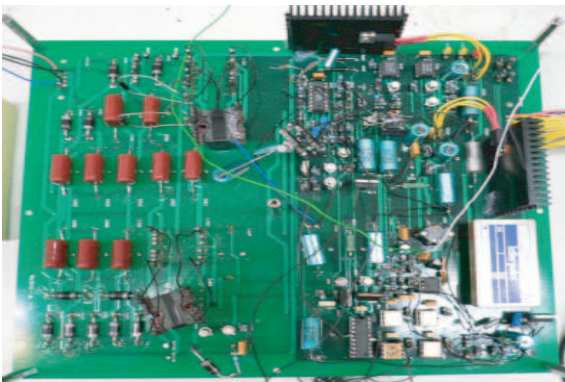

Fig. 4. Power Processing Unit

In STSAT-2, there are two NPN transistors in the ignition circuits to amplify current in the second transformer as shown figure 4. The NPN transistor which has a 500 of amplification  $h_{fe}$ . Then, it goes to the between electrodes to initiate plasma. It is the most important thing that we have to control and bypass an overcharging because of too much

current flow in the main power. Therefore, we proposed the feedback circuit as shown in figure 3 and figure 4 to protect the over charge voltage.

#### 3.2. Head and Feed Systems

The engine of STSAT-2 PPT consists of the two major parts such as heads and feeder of propellant including Teflon. The figure 5 shows the entire PPT system.

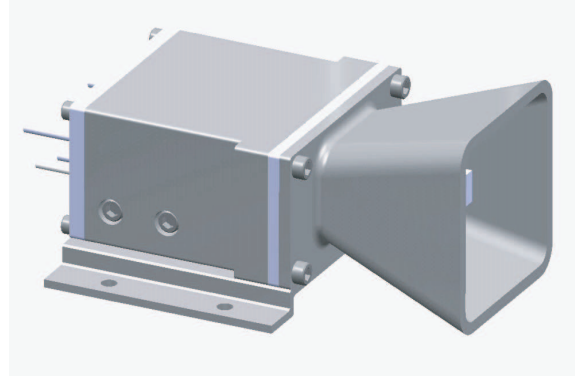

Fig. 5. Engine : Head and Feeder in the Rear Side View

As shown in figure 5, the head and feed systems have nozzle to avoid plume contamination with  $\pm 45$  degree of plasma out angle. When working the PPT in vacuum, the high voltage is applied to between electrodes and those have a possibility of electrical path vicinity the whole system. Owing to those problem, the structure of the head and feed systems including nozzle consists of insulation materials such as PL-PEM but not outgassed. In addition, it should be considered to minimize the thermal transfer from the honey comb panel to head and feed systems by using bracket. The main reason of bracket use is ease mount on the honey comb panel. Moreover, it is so ease to attach or detach the head and feed systems form the honey comb panel considering using the bracket.

#### 3.3. Capacitor

The capacitor used in STSAT-2 has a dimension of  $94mm \times 96mm \times 32mm$  as shown in figure 6. The STSAT-2 requires amount of  $2.0\mu F$  to produce an appropriate torque to the spacecraft, also around  $4.2J$  in electrical energy is stored in this capacitor.

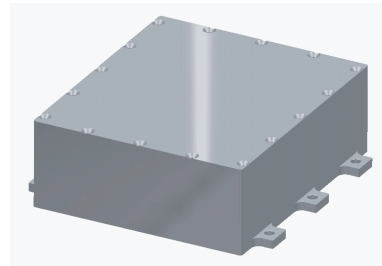

Fig. 6. Capacitor

During the operation, a number of changing and discharging electrical energy took place on the capacitor, then it has much thermal energy. Due to the problem, it is necessary to widen the area of capacitor to dissipate thermal energy along the capacitor body.

#### 4. The PPT Attachment

It is necessary that a spacecraft need six PPTs at each axis such as yaw, roll and pitch at least. Nevertheless, there is a only one PPT on pitch axis for unloading the momentum in STSAT-2. We can go over the following subsections regarding PPT location.

##### 4.1. Definition of Torque

As learned from college, the definition for torque is as follows

$$\tau = r \times F \quad (1)$$

, where  $r$  is the vector from body's center of mass to PPT and  $F$  is force generated by thrust.

##### 4.2. Body Fixed Coordinates

Normally, the coordinates for spacecraft are depending on case by case of designer. In STSAT-2, it is represented by the following figure 7. Roll-Axis is the ram direction of spacecraft, Yaw-Axis is the azimuth and finally rest one is perpendicular to the those ones. Also, figure 7 shows the location for PPT to produce torque to the center of mass as mentioned the previous subsection. According to Physics, torque will be represented by the length and force, respectively.

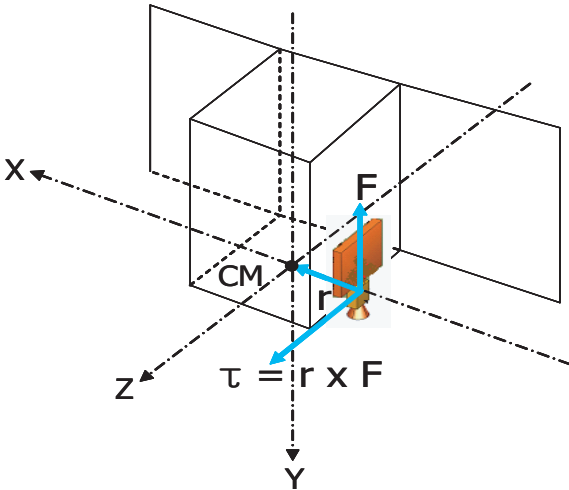

Fig. 7. Coordinates

STSAT-2 has a battery on the bottom, which weighs around  $7Kg$ . In accordance with the battery, the center of mass for STSAT-2 is near the bottom, therefore the PPT must be located on the bottom like figure 7. In this case, the PPT for pitch axis will be replaced to compensate the momentum energy.

#### 5. On-Orbit Validation Plan

The PPT experiment will be performed after some instruments have fulfilled its minimum mission requirements. It is desirable, but not required, to verify the operation of the PPT during the initial on-orbit check-out phase of the spacecraft. After the some instruments have achieved their fundamental objectives, the PPT experiment will be performed. The baseline on-orbit validation plan of PPT experimental is given as follows. There are four RWAs (Reaction Wheel

Assembly) in the STSAT-2. Each one has a its own axis to produce angular momentum.

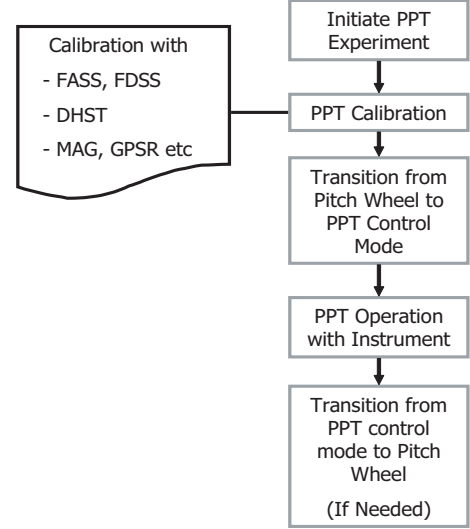

Fig. 8. Flow Chart on Validation Plan

#### 6. Experimental Result

##### 6.1. Impulse Bit and Specific Impulse

In this section we will look over the performance of STSAT-2's PPT according to a specific impulse<sup>1</sup> and an impulse bit<sup>2</sup>. When testing and experimenting the PPT, we used to some parameters as seen below.

- Charge Voltage : +1500V
- Capacitance : 1.6uF
- Operation Frequency : 1Hz

Before going into the specific impulse, we have to figure out a dynamic equation in satellite. So, it is represented by the following term in terms of mass and velocity.

$$p = mv \quad (2)$$

and

$$F = \dot{p} = \dot{m}v + m\dot{v} \quad (3)$$

To get a impulse bit from the thrust, we are going to use the following equations in terms of displacement, discharge current and permeability.

$$F = \frac{1}{2}\mu_0 \frac{h}{d} i^2 \quad (4)$$

, where the parameters in  $\mu_0$ ,  $h$  and  $d$ , are given from a measurement pendulum. And we have to only measure current  $i$  to obtain impulse bit by using a probe.

Upon the calculation of thrust, then impulse bit is summarized as following. It is represented by integral because of pulsed operation in PPT. In other hands, the entire torque generated by thrust should be integrated at every shot.

<sup>1</sup>Specific impulse means Isp

<sup>2</sup>Also, impulse bit means Ib

$$I_b = \int_0^t F dt \quad (5)$$

Finally, a specific impulse  $I_{sp}$  obtained as below, in here we used to impulse bit  $I_b$  and mass per shot  $m_b$ .

$$I_{sp} = \frac{I_b}{m_b g} \quad (6)$$

Therefore, we obtained the performance with  $13\mu g$  in mass per shot,  $25\mu Ns$  in impulse bit and around 800s in specific impulse.

## 6.2. High Voltage Charge and Discharge

From the above result, we obtained the following signal waveforms including ignition signal from the transistor of PPU. Figure 9 represents the charge and discharge of capacitor through pulse width modulation and figure 10 shows the level of noise when charging voltage by PPU. From the figures, the spark level of noise is within  $400mV$ . To reduce the spark noise in the PPU, we must consider EMI filter allocating at the input and output. As long as the EMI filter is placed at those points, unwanted signal does not interfere with the systems in the point of view of electronics, but not mechanics.

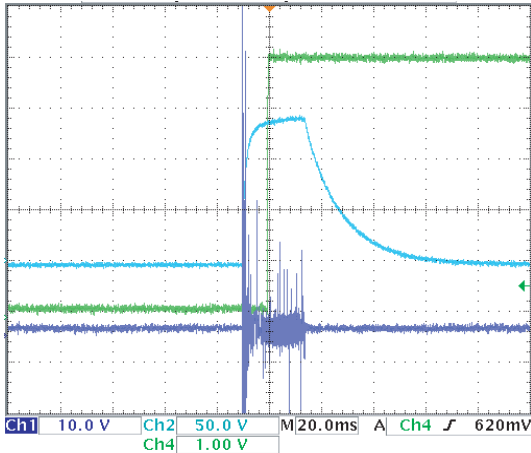

Fig. 9. Voltage Control

## 7. Conclusions

In this study, we obtained that the PPT has a lot of advantages such as power and mass in design of spacecraft compared to other chemical propulsion systems. In case of STSAT-2, the mass and power for the PPT are described in the previous sections. Therefore, advantages for STSAT-2 PPT are summarized as follows

- No valves and energy storage tanks
  - Simple mechanical structure (Simple fuel feeding system)
- So, light weight and small size for u-satellite
- Low impulse bit and high specific impulse
  - High reliability and performance

As a result of STSAT-2 PPT's development, we obtained that the angular momentum is around  $9mNm$  and the size of structure is as below.

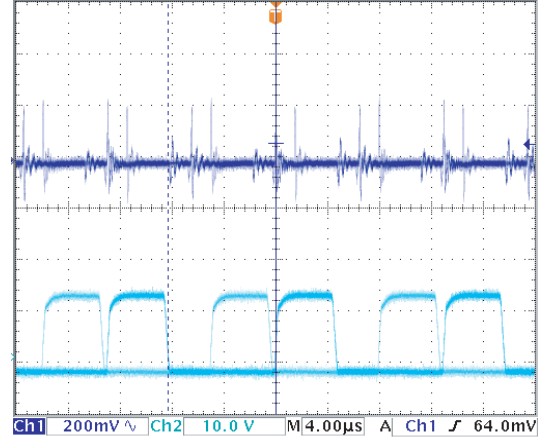

Fig. 10. The Magnitude of Noise Level

- PPU :  $230mm \times 180mm \times 30mm$
- Capacitor :  $94mm \times 96mm \times 32mm$
- Head and Feed Systems :  $60mm \times 50mm \times 50mm$

## Acknowledgements

The research contained herein was sponsored by the STSAT-2 Project of the Ministry of Science and Technology (MOST) in Korea.

## References

- [1] Goo-Hwan Shin, Myeong-Ryong Nam and Jong-Tae Lim, "Nonlinear Control and Analysis for PPT Uniform Energy Charge using Backstepping Methodology", *Proceedings of KSAS 1st Int. Session in 2003 KSAS 2003 Fall Conference*, vol. 1, Nov. 2003
- [2] Guman WJ and Nathanson DM. "Pulsed Plasma Microthruster Propulsion System for Synchronous Orbit Satellite." *J Spacecraft*, Vol. 7, No. 4, 409-415, April, 1970.
- [3] Vondra, R. J., and Thomassen, K. L., "Flight Qualified Pulsed Electric Thruster for Satellite Control," *Journal of Spacecraft and Rockets*, Vol. 11, No. 9, 613-617, 1974.
- [4] Brill, Y., Eisner, A., and Osborn, L., "The Flight Application of a Pulsed Plasma Microthruster, The NOVA Satellite," *AIAA-82-1956*, Nov. 1982.
- [5] Cassady, R. J., Morris, J. P., Vaughan, C. E., Willey, M. J., "New Attitude Control Strategies Using Pulsed Plasma Thruster Systems", *AAS 98-065*, February, 1998
- [6] Arrington, L. A., and Haag, T. W., "Multi-Axis Thrust Measurements of the EO-1 Pulsed Plasma Thruster," *AIAA-99-2290*, June 1999
- [7] Hoskins, WA, Wilson MJ, Willey MJ, Campbell, M and Chung S. "PPT Development Efforts at Primex Aerospace Company." *AIAA Paper 99-2291*, 35t
- [8] H.-S.Shin and J.-T.Lim., "On feedback linearization of nonlinear time-delay systems." *International Conference on control, Automation and Systems 2004* 1906 - 1908, 2004